

INTRODUCTION

- Exterior features	1
- Identification data – Location of identification data on vehicle	2
- Dimensions - Weights	3
- Performance – Fuel consumption	5
- Capacities	6
- Characteristics of lubricants	7

TECHNICAL DATA**ENGINE**

- Characteristics	8
- Typical curves	9
- Cylinder block/crankcase, crankshaft and associated components	10
- Counter balance shafts	14
- Cylinder head assembly and valve gear components	16
- Lubrication	19
- Cooling system – Fuel system – Supercharging	20

CLUTCH	22
---------------	----

GEARBOX AND DIFFERENTIAL	23
---------------------------------	----

PROPELLER SHAFT	26
------------------------	----

REAR DIFFERENTIAL	28
--------------------------	----

BRAKING SYSTEM	31
-----------------------	----

STEERING	32
-----------------	----

WHEELS	33
---------------	----

FRONT SUSPENSION	34
-------------------------	----

REAR SUSPENSION	35
------------------------	----

ELECTRICAL EQUIPMENT	37
-----------------------------	----

- Starting	38
- Recharging	40
- Electronic injection/ignition	42

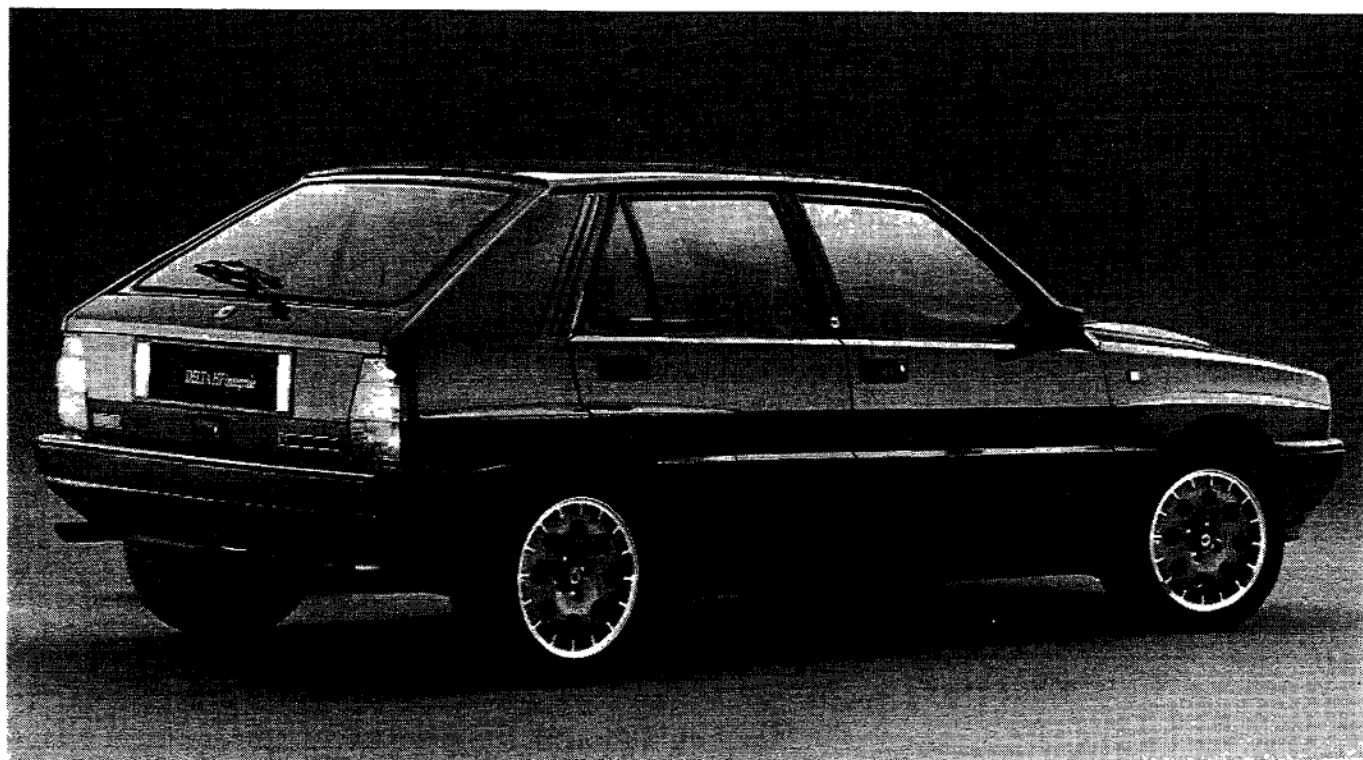
SPECIAL TOOLS	44
----------------------	----

TIGHTENING TORQUES	48
---------------------------	----



P1L01CA01

3/4 front view



P1L01CA02

3/4 rear view

Introduction

DELTA HF integrale 16v

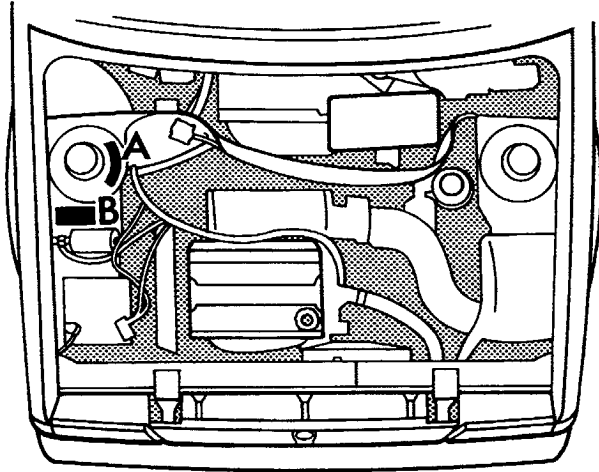
Identification data and location on vehicle

00.0

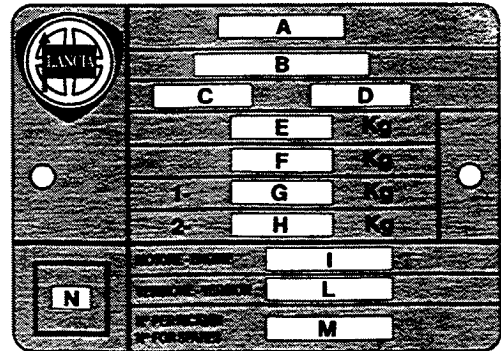
IDENTIFICATION DATA

	CHASSIS	ENGINE	VERSION	5 speed gearbox
1995 turbo 16v	ZLA 831 ABO	831 D5.000	831 ABO 26	•

LOCATION OF IDENTIFICATION DATA ON VEHICLE



F1Q007A02



F1X009A02

A Chassis details

- Vehicle type: (ZLA 831 ABO)
- chassis manufacture number.

NOTE The engine type and number are stamped on the cylinder block/crank-case behind the engine oil cartridge filter.

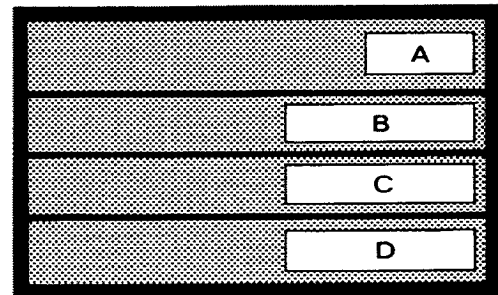
B V.I.N. Plate (EEC regulations)

- A. Name of manufacturer.
- B. Type approval number.
- C. Vehicle type identification code.
- D. Chassis manufacture number.
- E. Maximum authorized weight of vehicle fully laden.
- F. Maximum authorized weight of vehicle fully laden plus tow.
- G. Maximum authorized weight on first axle (front).
- H. Maximum authorized weight on second axle (rear).
- I. Bodywork version code.
- L. Engine type.
- M. Spares number.
- N. Correct value of smoke absorption coefficient (for Diesel engines).

Body paintwork identification plate

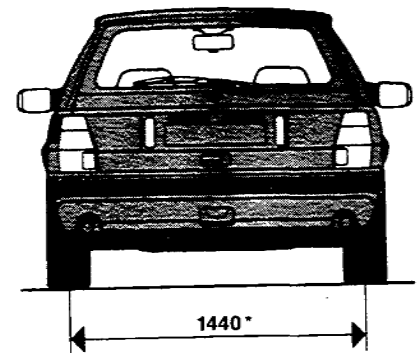
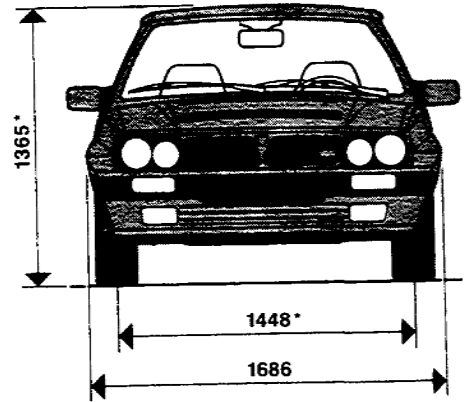
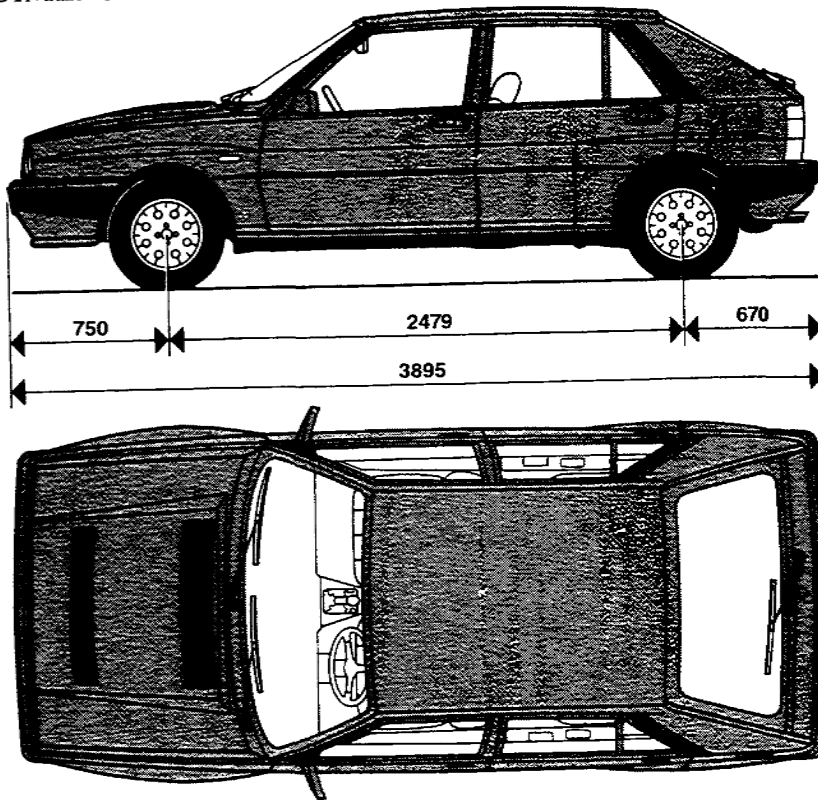
It is inside the bonnet lid

- A. Paint manufacturer
- B. Description of colour
- C. Colour code
- D. Colour code for retouches or spraying



F1Q006A01

DIMENSIONS



P1L03CA01

(* Unladen car

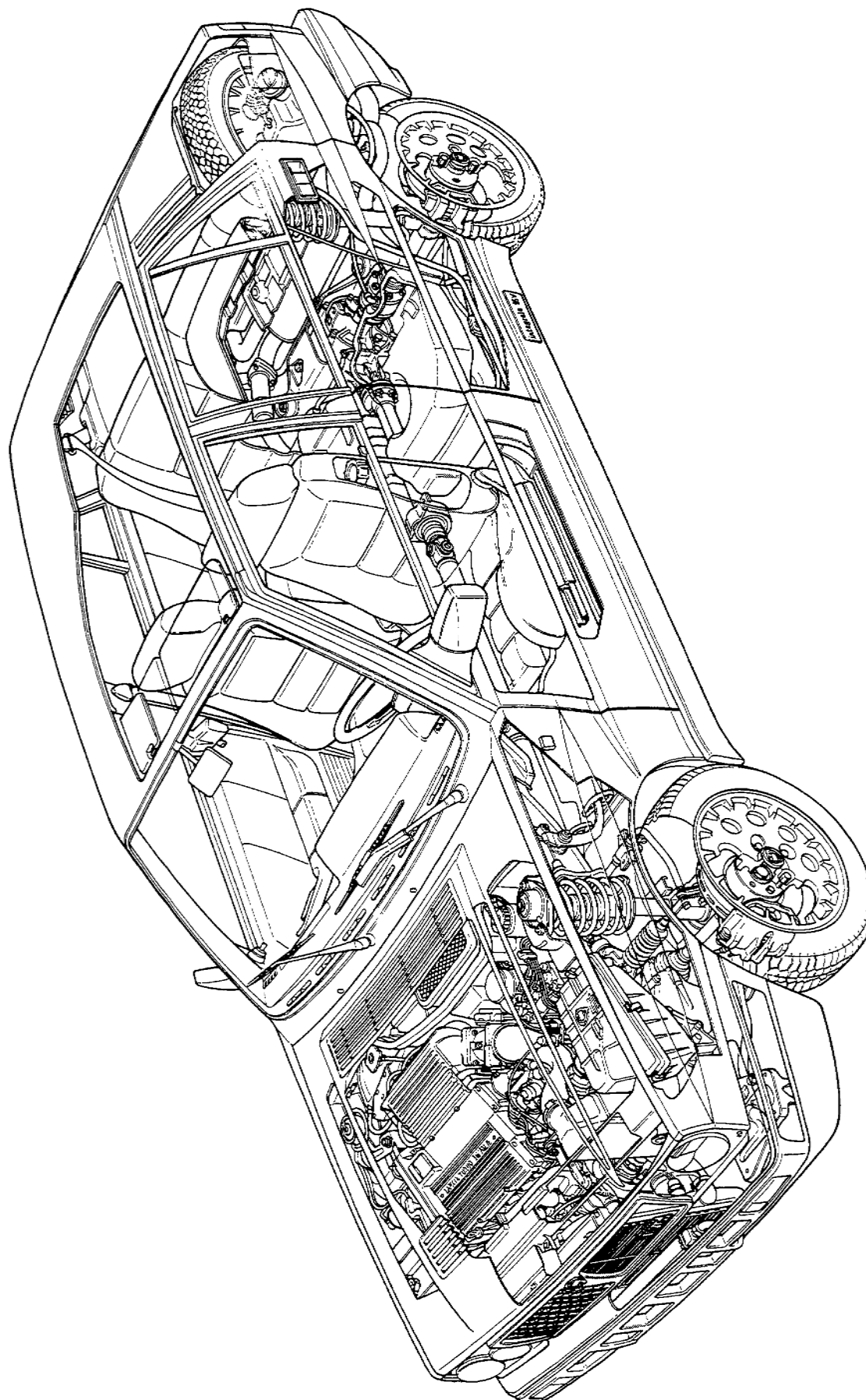
Luggage compartment capacity with rear seat backrest in normal position: 200 dm³ (7.06 cu ft).

Luggage compartment capacity with rear seat backrest folded down: 940 dm³ (33.19 cu ft).

WEIGHTS (values in kg)


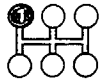
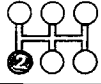
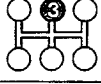

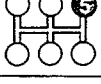
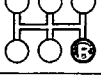
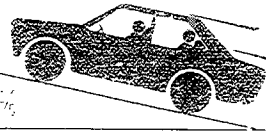
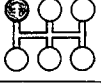
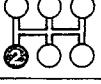
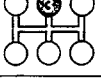
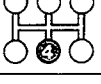
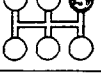
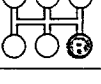

		1250
+ 450		1700
		910
+		790
+		1200

00.0



LAYOUT OF MECHANICAL COMPONENTS ON VEHICLE

P1L04CA01











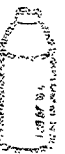
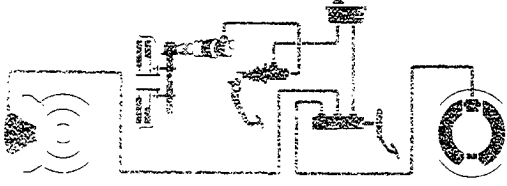

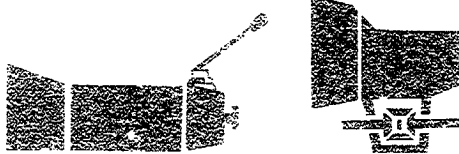

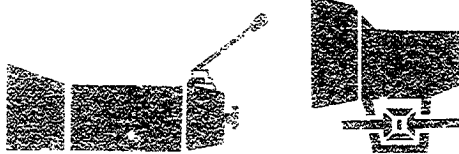





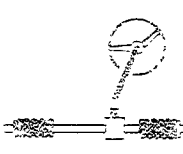

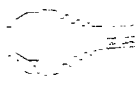




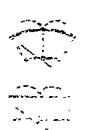
<p>Speed kph</p> 		60
		95
		140
		185
		220
		60
<p>Maximum climbable gradient</p> 		58
		41
		25
		17
		12
		68
<p>EEC fuel consumption figures (litres/100 km)</p> 	Urban cycle (A)	11,2
	Constant speed 90 kph (B)	7,9
	Constant speed 120 kph (C)	10,5
	Average consumption (CCMC proposal) $\frac{A+B+C}{3}$	9,8

Introduction

Capacities

DELTA HF integrale 16v


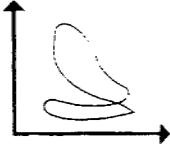

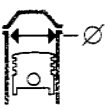

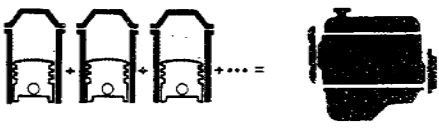
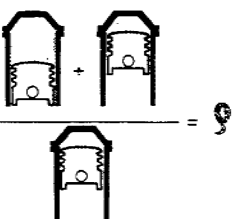
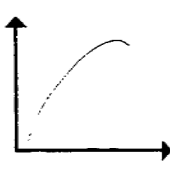
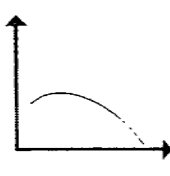
00.0

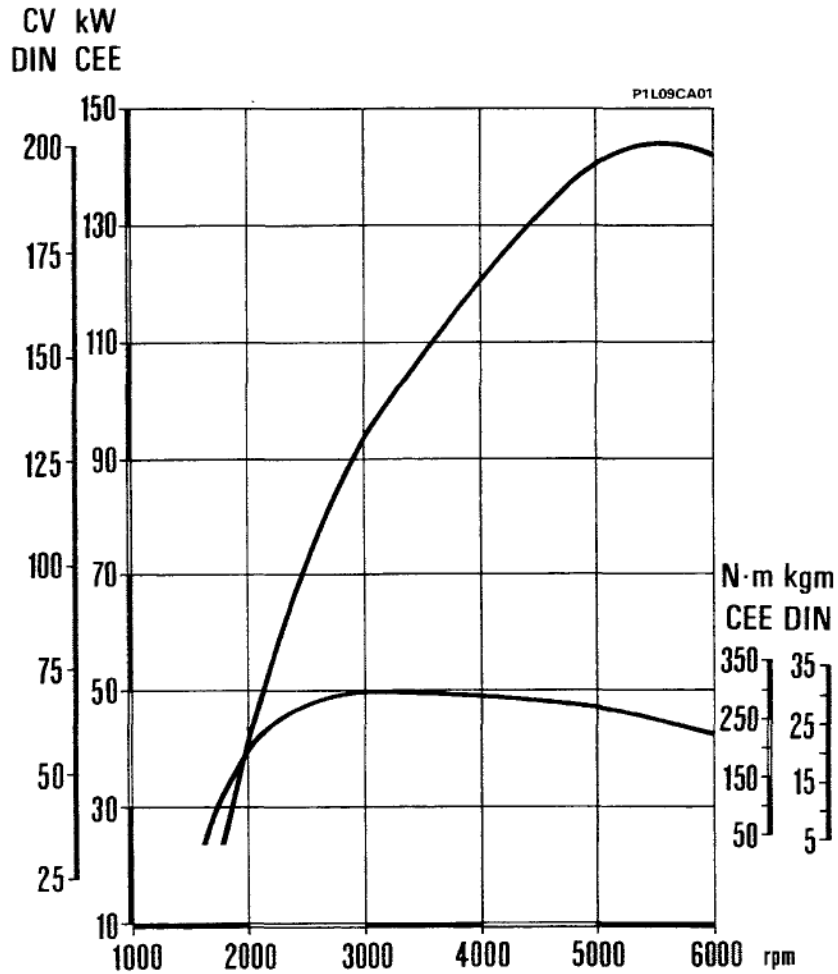
Capacities	Unit		Quantity				
			dm ³	(kg)			
 Petrol O.R. 95	 	57	-				
 50% + 	 Total capacity of cooling system	6,2	-				
 SELENIA (SAE 15W40)	Total capacity 	5,9	5,0				
	Partial capacity (periodic replacement)  	-	4,80				
 TUTELA DOT 4	 Total capacity of hydraulic clutch and braking system	0,56	-				
 a = TUTELA ZC 80S		without ABS	-				
		with ABS	-				
 b = TUTELA GI/A		a	3,80	3,40			
 b = TUTELA GI/A		b	-	-			
 TUTELA W 90/M DA	a	 Self-locking	a	-	-		
	b		b	1,1	1		
 a = TUTELA GI/A			a	0,75	-		
			b	-	-		
 c = TUTELA MRM2	c		c	-	0,10		
 +  Distilled water		3%			2	-	
		~ - 10 °C					50%
		~ - 20 °C					100%

Name of product	Description International designation	Usage
SELENIA SAE 15 W/40	Multigrade engine oil containing polyalphaolefines and external synthetics. Exceeds API SG and CCMC - G2/G3 specifications. Cuna NC 610 01 G2	Temperature - 15°C ÷ > 40°C
VS ⁺ Supermultigrado SAE 10 W/30 SAE 15 W/40	Low ash content detergent oil for petrol engines. Service API "SF". Exceeds European specification CCMC-G2/G3	Temperature below -15°C ÷ 30°C Temperature - 15°C ÷ > 40°C
SELENIA Turbo Diesel SAE 15 W/40	Multigrade engine oil containing polyalphaolefines and external synthetics. Exceeds standards API CD and CCMC-PD1. Cuna NC 610 01 CL. PD1.	Temperature - 15°C ÷ > 40°C
VS Diesel Supermultigrado SAE 10 W/30 SAE 15 W/40	Oil for diesel engines. Service API "CD". Satisfies standards MIL-L-2104 D and CCMC-PD1	Temperature below -15°C ÷ 30°C Temperature - 15°C ÷ > 40°C
TUTELA ZC 80S	SAE 80/W oil. Satisfies standards MIL-L-2105 and API GL4	Manual gearboxes and differentials
TUTELA ZC 90	Non EP SAE 80 W/90 oil. for manual gearboxes. containing anti-wear additives.	Gearboxes and non hypoid differentials
TUTELA W 90/M DA	Special EP SAE 80 W/90 oil for normal and self-locking differentials. Satisfies standards MIL-L-2105 C and API GL5	Hypoid differentials Self-locking differentials. Steering boxes
TUTELA GI/A	DEXRON II type oil for automatic transmissions.	Automatic gearboxes. Idroguide
TUTELA CVT	Oil for continuous variation automatic transmissions.	Continuous variation automatic transmissions
TUTELA JOTA 1	Lithium soap based grease. consistency NLGI = 1	Greasing the vehicle except for components particularly exposed to water requiring special greases
TUTELA MRM2	Water-repellant. lithium soap based grease containing molybdenum disulphide. consistency NLGI = 2	Constant velocity joints
TUTELA MR3	Lithium soap based grease. consistency NLGI = 3	Wheel hub bearings. steering rod. various components
TUTELA DOT 3 TUTELA DOT 4	Fluid for hydraulic brakes. meeting USA FMVSS standards no. 116, SAE J 1703, ISO 4925, CUNA NC-956-01	Hydraulic brakes and hydraulically operated clutches
K 854	Lithium soap based grease. consistency NLGI = 000. containing molybdenum disulphide	Rack and pinion steering boxes
SP 349	Special castor oil and sodium soap based grease containing graphite and molybdenum disulphide. compatible with brake fluid and brake circuit rubber seals	Load proportioning valve Load proportioning valve rod bush
Autofà n° 9 DP1	Alcohol based liquid detergent	To be used undiluted or diluted in windscreen washers and headlamp washers
Liquido Paraflu ^{II} FIAT	Mono-ethylene glycol based anti-freeze for cooling system	Cooling circuits. Percentage to be used 35% up to - 25°C 50% up to - 35°C
Diesel Mix	Additive for diesel fuel with protective action for diesel engines	To be mixed with diesel fuel (17 cc per 10 litres)

00.10

CHARACTERISTICS

			831 D5.000
	Cycle	OTTO 4 stroke	
	Number of cylinders	4	
	Cylinder liner (bore)	mm	84
	Stroke	mm	90
	Capacity	cc	1995
	Compression ratio	$8 \pm 0,15$	
	Max power EEC	kW (CV)	144 (200)
		rpm	5500
	Max torque EEC	daNm (kgm)	29,8 (31)
		rpm	3000



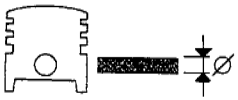




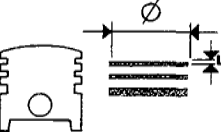
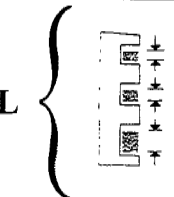





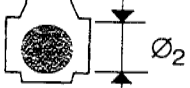
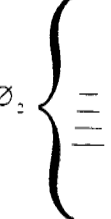
Typical power curves obtained by EEC method

The power curve illustrated can be obtained with the engine overhauled and run in, without a fan, with a silencer and air filter fitted at sea level.

Test bench cycles of overhauled engines

During the bench test of the overhauled engine it is not advisable to run the engine at maximum speed, but to stick to the figures given in the table; complete the running in of the engine in the vehicle.

Test speed (rpm)	Time in minutes	Load on the brakes
800 ÷ 1000	10'	no load
1500	10'	no load
2000	10'	no load

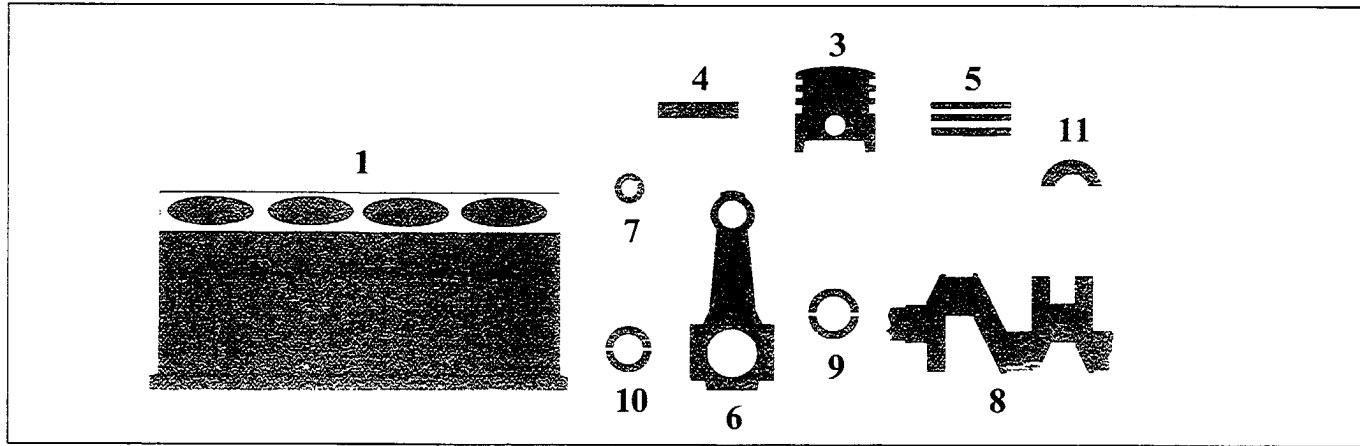
DESCRIPTION		Values in mm			
4			1	21,991 ÷ 21,994	
			2	21,994 ÷ 21,997	
Gudgeon pin		∅ LANCIA >	0,2		
4-3		Gudgeon pin - Housing	0,002 ÷ 0,008		
3			1	1,535 ÷ 1,555	
			2	2,020 ÷ 2,040	
			3	3,967 ÷ 3,987	
5			1	1,478 ÷ 1,490	
			2	1,987 ÷ 1,990	
			3	3,925 ÷ 3,937	
Piston rings		∅ LANCIA >	0,4		
5-3			1	0,045 ÷ 0,077	
			2	0,030 ÷ 0,062	
			3	0,030 ÷ 0,062	
5-1	 		1	0,30 ÷ 0,50	
			2	0,30 ÷ 0,50	
			3	0,25 ÷ 0,40	
6			∅ ₁	24,988 ÷ 25,021	
				1	53,904 ÷ 53,910
				2	53,898 ÷ 53,904
Big end bearing housing		∅ ₂	3	53,892 ÷ 53,898	

Technical data

DELTA HF integrale 16v

Engine: cylinder block/crankcase, crankshaft and associated components

00.10



DESCRIPTION		Values in mm	
<p>7 Small end bush housing</p>	\varnothing_1		25,065 ÷ 25,090
	\varnothing_2	1	22,004 ÷ 22,007
		2	22,007 ÷ 22,010
4-7	Gudgeon pin Small end bush		0,010 ÷ 0,016
7-6	Small end bush Bush housing		0,044 ÷ 0,102
<p>8 Main journals Crank pins</p>	\varnothing_1	A	52,998 ÷ 53,004
		B	52,992 ÷ 52,998
		C	52,986 ÷ 52,992
	\varnothing_2	1	50,799 ÷ 50,805
		2	50,793 ÷ 50,799
		3	50,787 ÷ 50,793
	L	27,975 ÷ 28,025	
<p>9 Crankshaft bearings</p>	L	A	1,838 ÷ 1,844
		B	1,844 ÷ 1,850
		C	1,850 ÷ 1,856
	\varnothing		0,254 ÷ 0,508


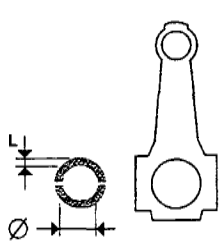

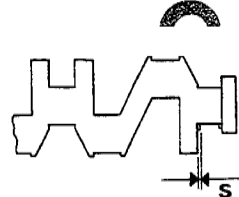

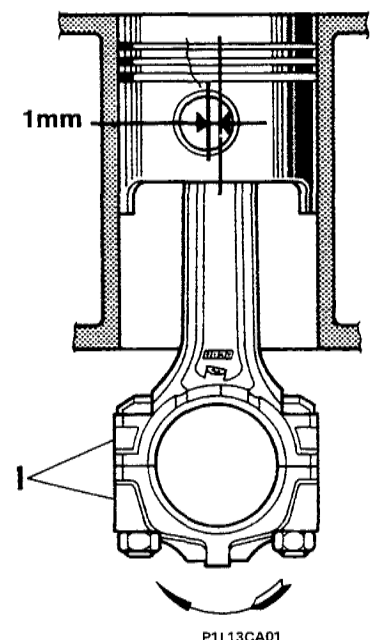
DESCRIPTION		Values in mm	
9-8	 Crankshaft bearings -Main journals	0,025 ÷ 0,049	
10	 Big end bearings	L { A B C	
		A	1,527 ÷ 1,533
		B	1,533 ÷ 1,539
		C	1,539 ÷ 1,545
	Ø LANCIA <	0,254 ÷ 0,508	
10-8	 Big end bearings -Main journals	0,033 ÷ 0,057	
11	 Thrust washers	S	
		S LANCIA >	0,127
11-8	 Crankshaft end float	0,055 ÷ 0,305	

Diagram showing fitting of connecting rod-piston assembly and direction of rotation in engine

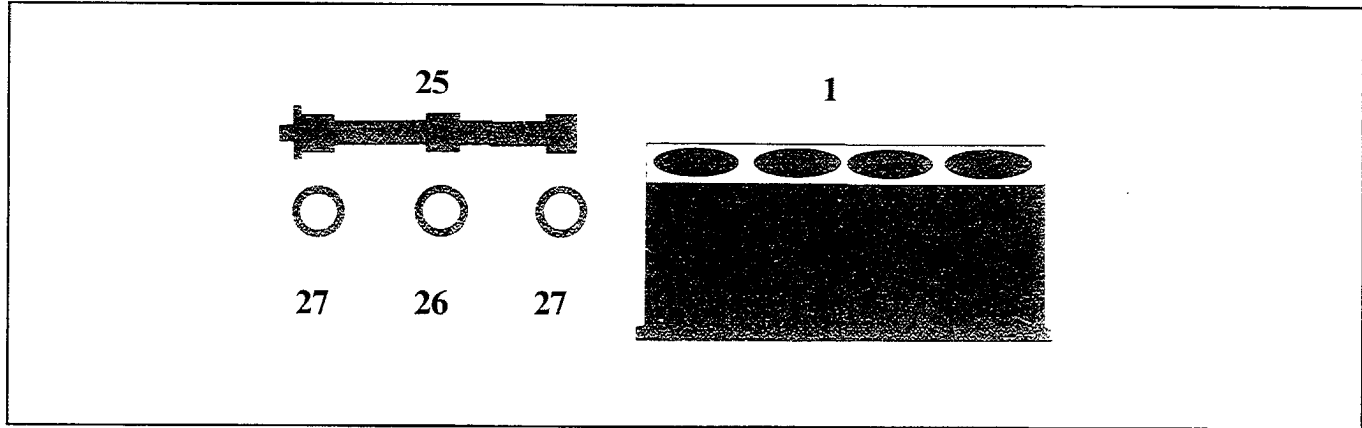
1 = Area where matching number of cylinder bore to which connecting rod belongs is stamped.

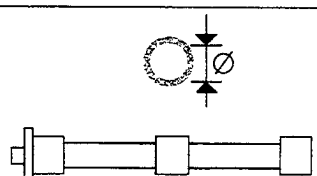
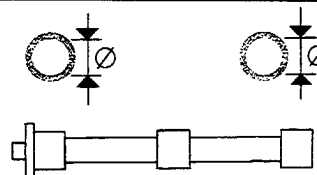
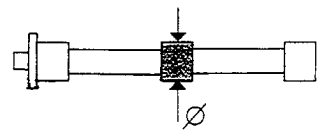
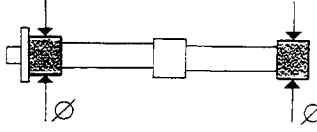




The arrow shows the direction of rotation of the engine as seen from the timing side.

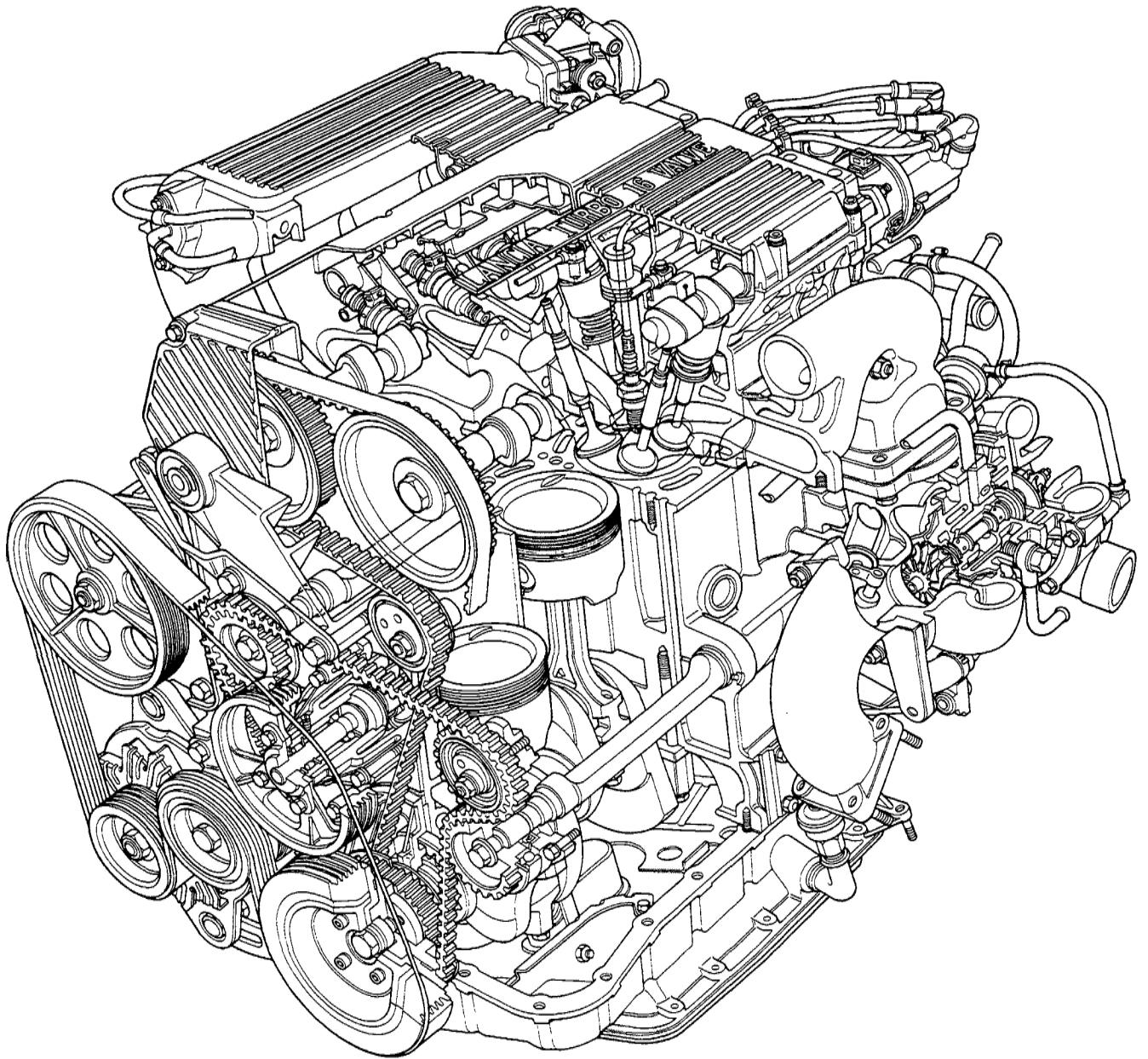
1 mm = Gudgeon pin offset on the piston.



00.10



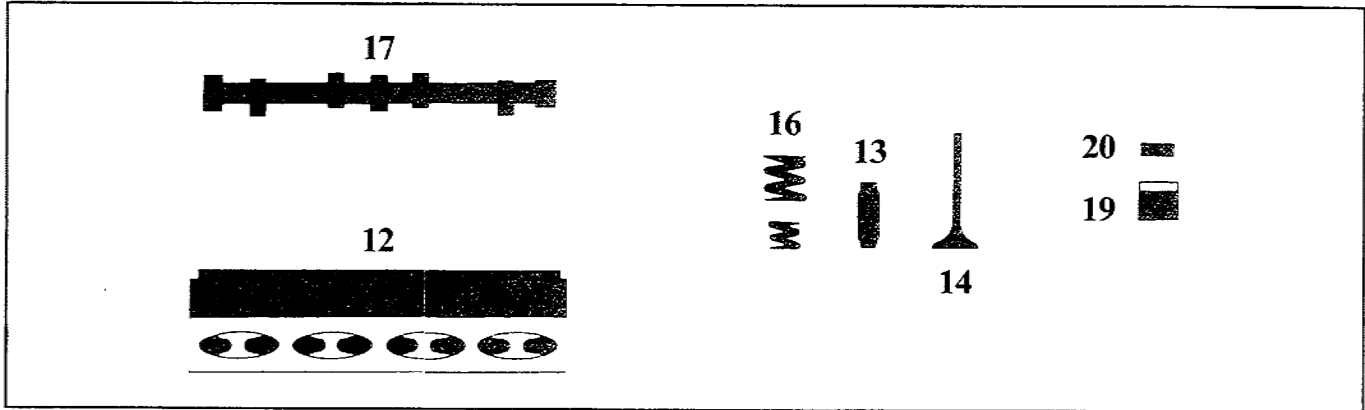
DESCRIPTION		Values in mm
25	Counter balance shafts	n° 2
	Shaft control	by toothed belt
26	 Centre bush for counter balance shafts in housing	\varnothing 37,020 ÷ 37,040
27	 Ball bearings for counter balance shafts	\varnothing 19,990 ÷ 20,000
25	 Counter balance shaft centre bearing	\varnothing 36,945 ÷ 36,960
25	 Counter balance shaft bearings	\varnothing 19,980 ÷ 19,993
26-1	 Bush for shaft Cylinder block/crankcase housing	0,080 ÷ 0,150
25-26	 Shaft bearing - Bush	0,060 ÷ 0,095
27-1	 Ball bearings Cylinder block seats	+0,011 ÷ - 0,025
25-27	 Shaft bearings Ball bearings	+0,020 ÷ - 0,003



P1L15CA01

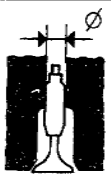
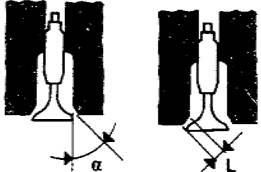

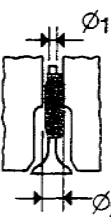
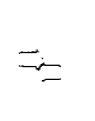

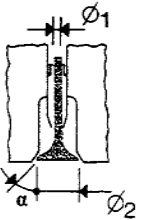
Engine, partial cross section


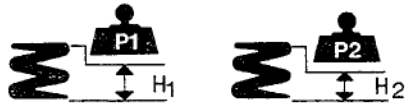

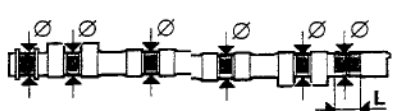



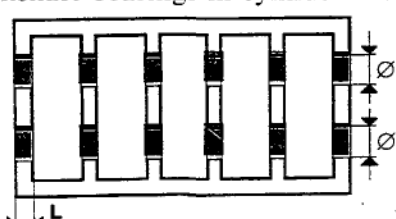
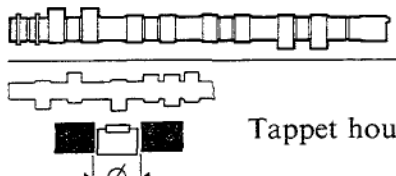

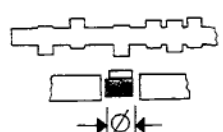
00.10



DESCRIPTION

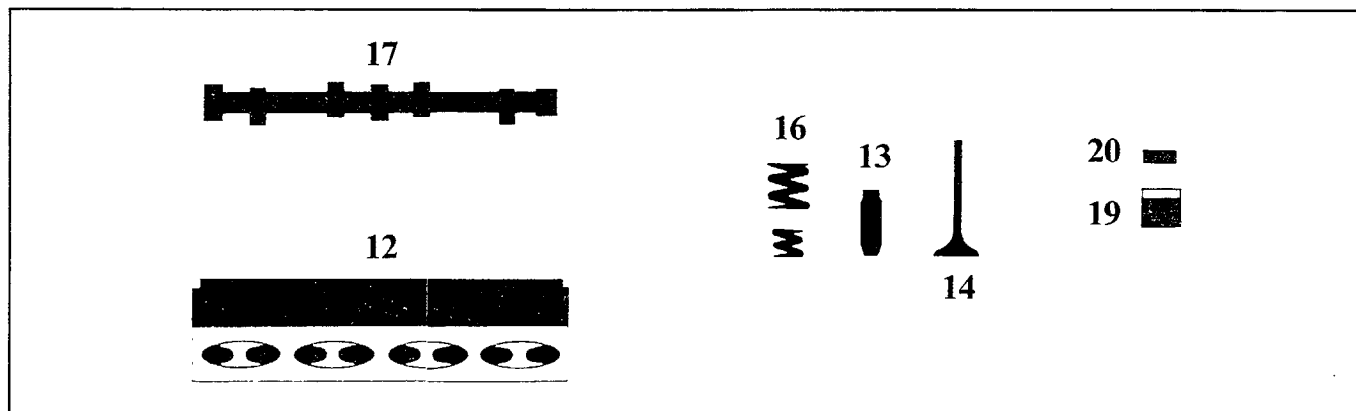
Values in mm

	Valve guide bore in cylinder head	\varnothing	$13,950 \div 13,977$
12 	Valve seats	α L	$45^\circ \pm 5'$ circa 2
	Volume of combustion chamber in cylinder head	cc	-
13 	Valve guide	\varnothing_1 \varnothing_2	$7,022 \div 7,040$ $14,010 \div 14,030$ 0,05-0,10-0,25
13-12 	Valve guide Bore in cylinder head		$0,033 \div 0,080$
14 	Valves	\varnothing_1 \varnothing_2 α \varnothing_1 \varnothing_2 α	$6,974 \div 6,992$ $34,300 \div 34,500$ $45^\circ 30' \pm 5'$ $6,974 \div 6,992$ $28,300 \div 28,500$ $45^\circ 30' \pm 5'$

DESCRIPTION		Values in mm	
14-13	 Valve - Valve guide		0,030 ÷ 0,066
15	 Internal valve spring	P ₁	14,12 ÷ 15,10 daN
		H ₁	31
		P ₂	26,39 ÷ 28,74 daN
		H ₂	21,5
16	 External valve spring	P ₁	36,68 ÷ 39,6 daN
		H ₁	36
		P ₂	55,91 ÷ 60,82 daN
		H ₂	26,5
17	 Camshaft bearings	∅	28,480 ÷ 28,495
		L	19,670 ÷ 19,750
17	 Cam lift		8,6
			7,5
12	 Camshaft bearings in cylinder head	∅	28,545 ÷ 28,570
		L*	19,450 ÷ 19,520
12	 Tappet housings	∅	37,000 ÷ 37,025
17-12	 Camshaft bearings Camshaft housing	radial	0,050 ÷ 0,090
		axial	0,150 ÷ 0,300
19	 Tappet	∅	36,975 ÷ 36,995

* Rear cap measurement

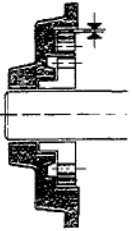
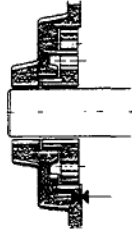


00.10



DESCRIPTION		Values in mm
19-18	<p>Tappet Housing in cylinder head</p>	0,005 ÷ 0,050
20	<p>Shim</p> <p>$S \left(\begin{matrix} \text{A} \\ 0,05 \end{matrix} \right)$</p>	3,25 ÷ 4,70
17-20	<p>clearance for timing check</p>	0,80
	<p>operational clearance</p>	0,80
		0,35 ± 0,04
		0,40 ± 0,03

TIMING ANGLES

inlet	<p>opens B.T.D.C.</p>	8°
	<p>closes A.B.D.C.</p>	35°
exhaust	<p>opens B.T.D.C.</p>	30°
	<p>closes A.B.D.C.</p>	0°

		Values in mm
Engine lubrication system		forced feed by means of lobe gear pump with cartridge oil filter in series
Oil pump		lobe gears
Pump operated		through crankshaft
Oil pressure relief valve		incorporated in crankshaft front cover
 <p>between pump casing housing and driven gear</p>		0,080 ÷ 0,186
 <p>between the upper side of the gears and the pump cover</p>		0,025 ÷ 0,056
Full flow		cartidge filter
Insufficient oil pressure sender unit		electrical
 <p>Operating pressure at a temperature of 100°C</p>		3,4 ÷ 4,9 bar
 <p>Oil pressure relief valve spring</p>	P ₁	11,1 ÷ 12,1 daN
	H ₁	35,3

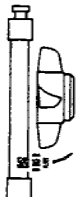



Technical data

DELTA HF integrale 16v

Engine: cooling system-fuel system-supercharging

00.10

COOLING SYSTEM

Cooling circuit	coolant circulation via centrifugal pump, radiator and two speed electrical fan operated by thermostatic switch	
Water pump operated	through belt	
 Thermal switch to engage fan		86° ÷ 94°C
		81° ÷ 89°C
Engine cooling water thermostat	opening	81° ÷ 85°C
	max opening	91° ÷ 93°C
	valve travel	≥ 7,5 mm
Clearance between impeller blades and pump casing		0,6 ÷ 1 mm
Pressure for checking system water tightness	0,98 bar	
Pressure for checking exhaust valve on expansion tank	0,98 bar	

FUEL SYSTEM - Description

Type	I.A.W. (MPI) injection/ignition
Fuel regulation pressure	2,5 bar
Pump (type)	electrical
Pump capacity (14 V supply with engine idling)	≥ 120 litres/h

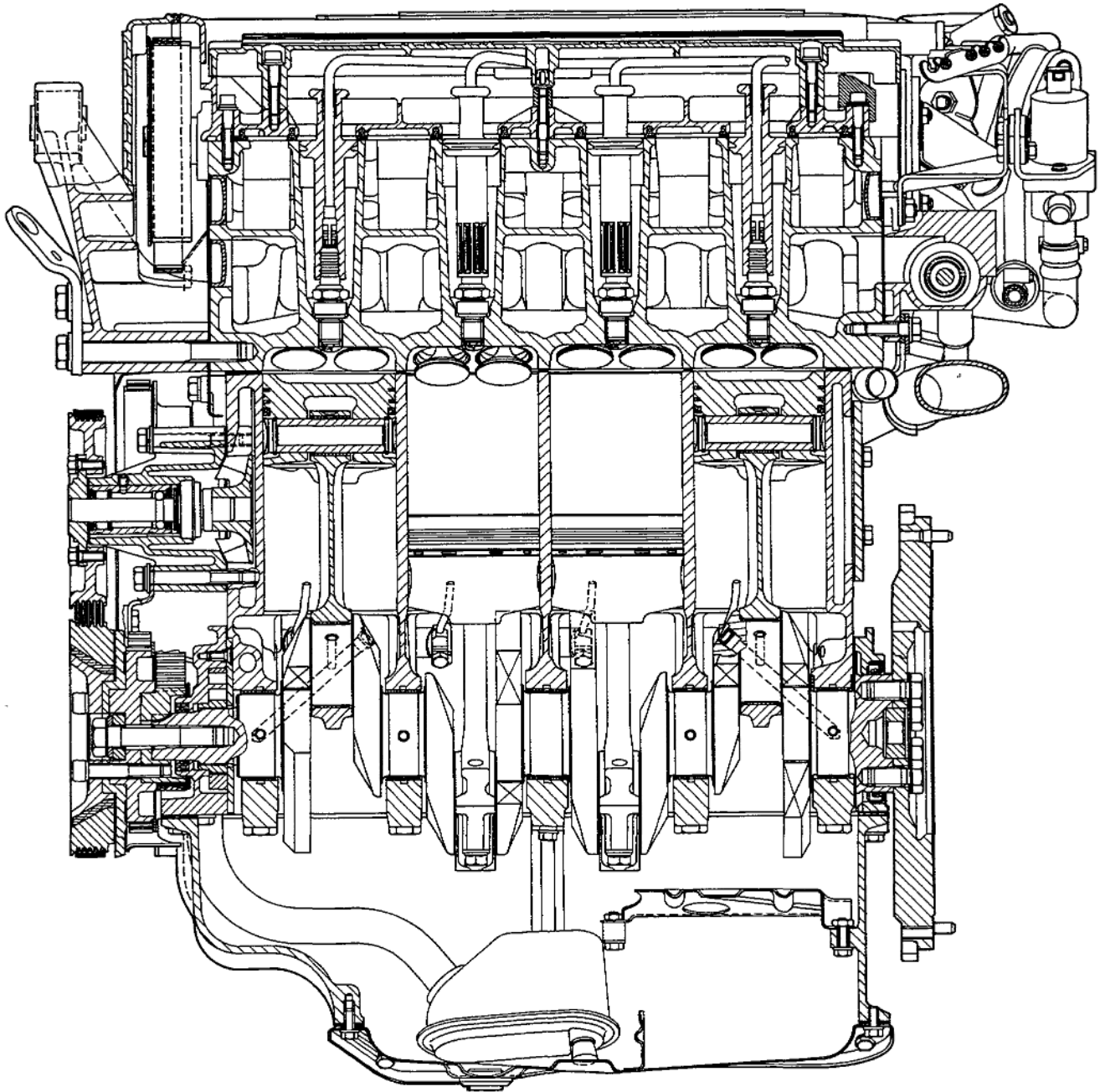
SUPERCHARGING (with turbocharger operated by exhaust gases with "Waste-gate" valve)

Turbocharger type:	Garrett T3
Maximum supercharging pressure	1 bar

Checking engine idle speed and carbon monoxide emissions

Engine idle speed	rpm	850 ÷ 950	(750 ÷ 850) (*)
Co idle emissions	(%)	1,5 ± 0,5	



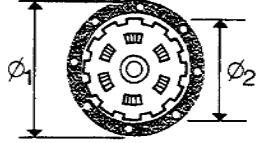
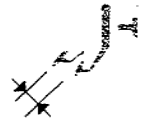
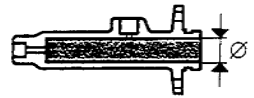

(*) With VAE valve disconnected



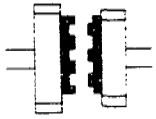


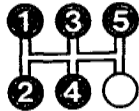


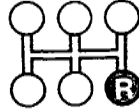

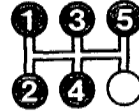

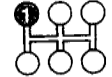
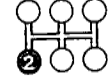
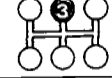
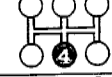
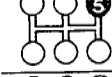



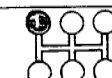
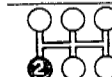
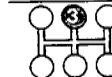
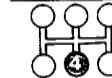
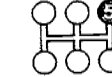
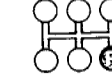
P1L21CA01

Longitudinal section of engine

00.18

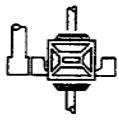




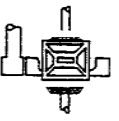
		Values in mm	
Type		dry, single plate	
Operating mechanism		diaphragm spring	
Spring loading	daN	650	
Lining		Ø1	236
		Ø2	154
	Distance between pedal in end of travel position and rest position	142	
Clutch release		hydraulic	
	Clutch pump	Ø	18,75 (3/4")
	Operating cylinder	Ø	25,4 (1")

GEARBOX


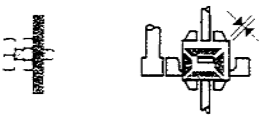
 Synchronizers	spring ring (Porsche type) 	-
	baulk ring type 	
 Gears	straight toothed 	
	helical toothed 	
 Gear ratios		3,500
		2,176
		1,524
		1,156
		0,917
		3,545
 Crown wheel and pinion reduction	56/18 (3,11)	
 Ratio at the wheels		10,888
		6,767
		4,739
		3,595
		2,851
		11,025

00.21-27

















CENTRE DIFFERENTIAL: Epicyclic, with torque shared between front and rear axles with a ratio of 47/53

 <p>Differential internal casing bearing</p>	 <p>conical roller bearings</p>
 <p>Adjustment of bearing pre-loading</p>	 <p>by shims</p>
 <p>LANCIA $\left(\begin{matrix} \text{—} \\ \text{—} \\ \text{—} \end{matrix} 0,05 \right)$ mm</p> <p>Thickness of shims</p>	<p>1,00 ÷ 1,60</p>
 <p>Interference to obtain exact bearing pre-loading</p> <p>mm</p>	<p>bearings not pre-loaded = 0,12 bearings pre-loaded (350 daN) = 0,08</p>

FRONT DIFFERENTIAL

 <p>Clearance between satellite and planet gears</p> <p>mm</p>	<p>$\leq 0,10$</p>
 <p>Adjustment of clearance between planet and satellite gears</p>	<p>cannot be adjusted</p>

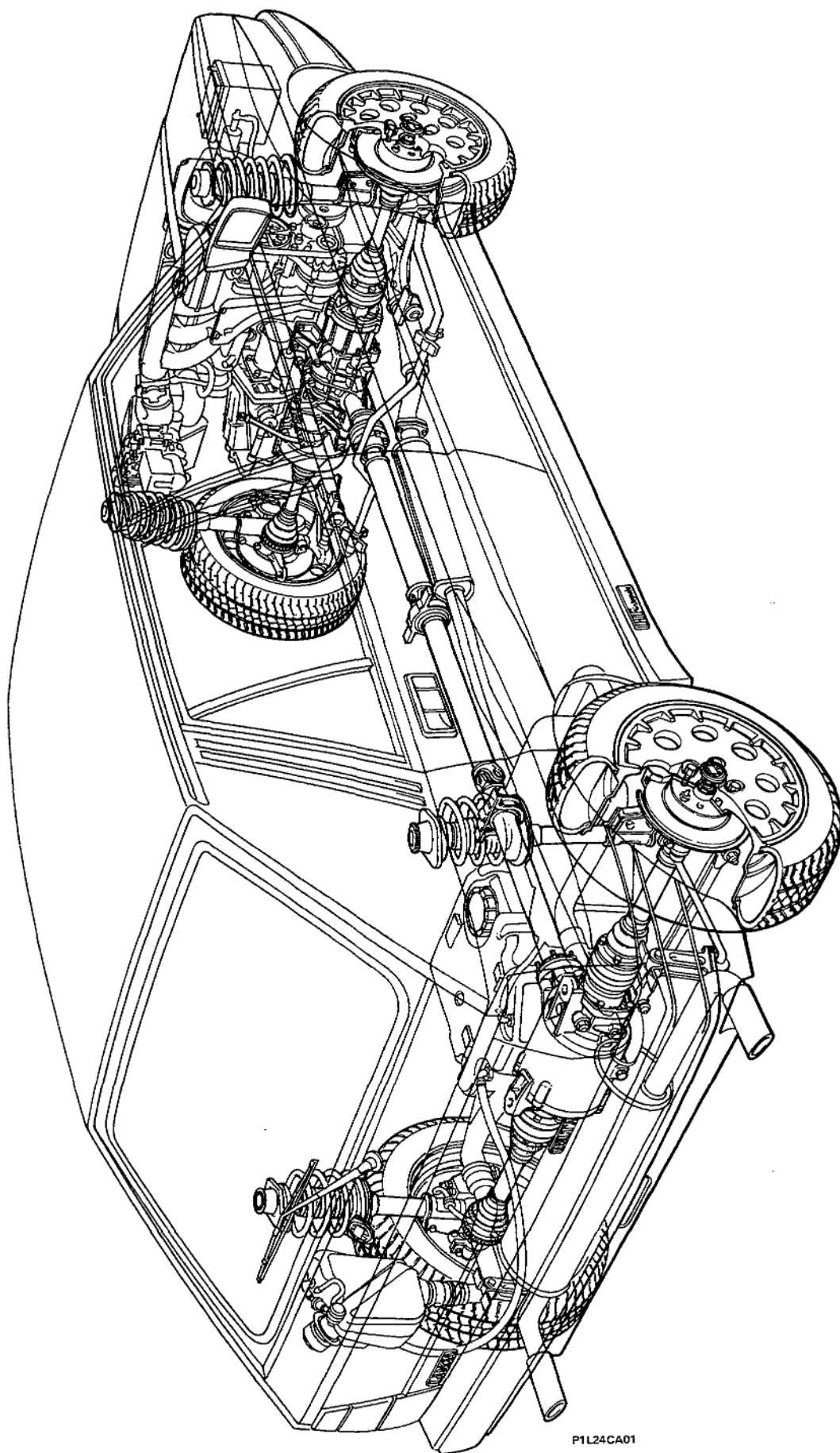
IDLER GEAR

 Final drive ratio	<p>43/19 (2,263)</p>
 Crown wheel bearing rolling torque	<p>daNm 0,18 ÷ 0,20</p>
 Adjustment of crown wheel bearing	 by shims
 LANCIA  0,025 mm	<p>1,475 ÷ 2,90</p>
 Adjustment of bevel pinion position	 by shims
 LANCIA  0,02 mm	<p>2,55 ÷ 3,35</p>
 Bevel pinion bearing rolling torque	<p>daNm 0,08 ÷ 0,12</p>
 Clearance between pinion and crown wheel	<p>mm 0,08 ÷ 0,15</p>
 Adjustment of clearance between pinion and crown wheel	 by shims
 LANCIA  0,025 mm	<p>1,475 ÷ 2,90</p>

00.24










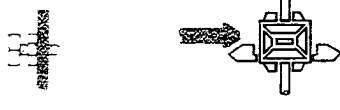

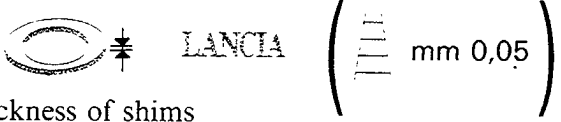
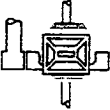



Type		in three sections
Supports		$2 \left\{ \begin{array}{l} 1 \text{ on the centre section with a ball bearing on the support} \\ 1 \text{ on the rear section with a ball bearing inside the support fixed dust cover} \end{array} \right.$
Sliding constant velocity joints		1, on the front section
Universal joints		2, on the centre section
Splined joint		1, on the rear section
Spider radial clearance	mm	0,01 ÷ 0,04
Thickness of shims for adjusting spider radial clearance	mm	1,50-1,53-1,56-1,59-1,62
Clearance between joint splines	mm	0,175 ÷ 0,350





LAYOUT OF POWER TRANSMISSION COMPONENTS

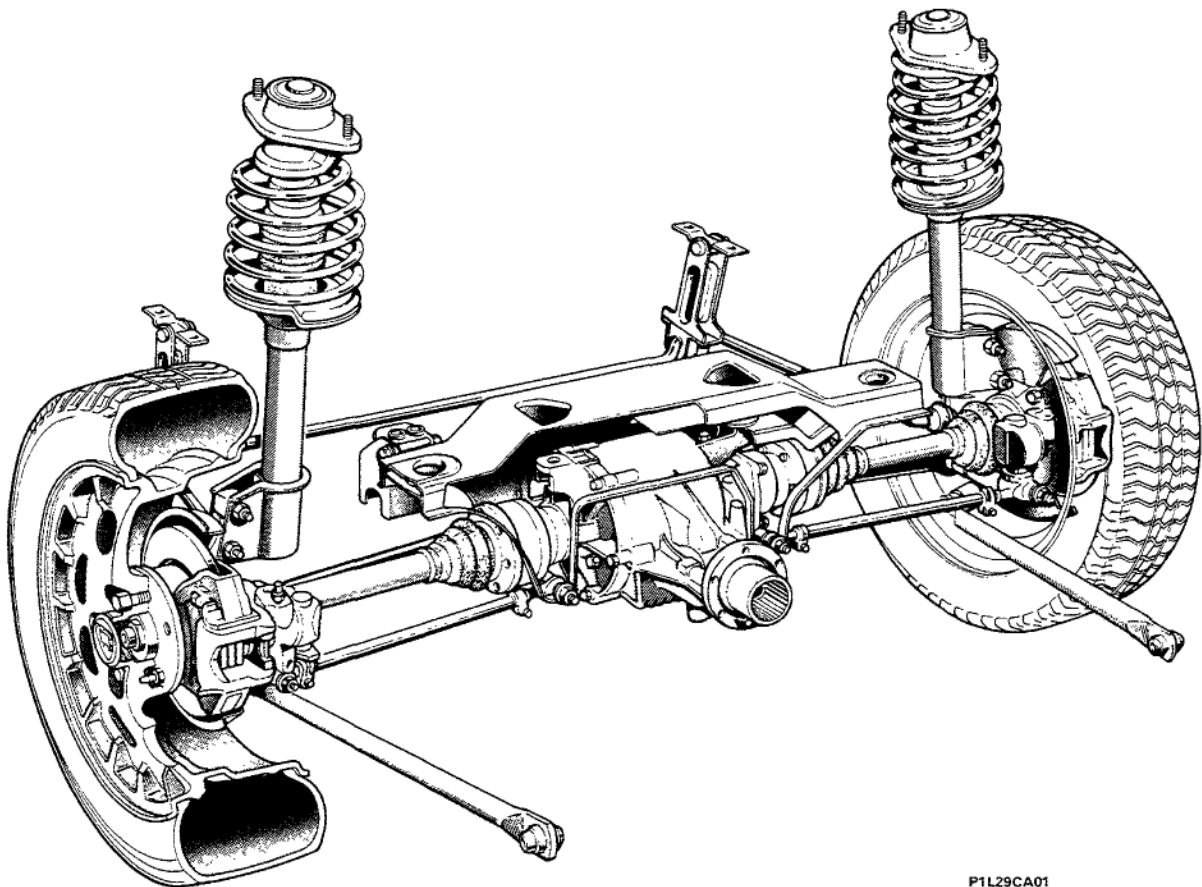


P1L24CA01

00.27

 <p>Final drive ratio</p>	<p>19/43 (2,263)</p>
 <p>Ratio at the wheels</p>	 <p>10,888</p>
	 <p>6,767</p>
	 <p>4,739</p>
	 <p>3,595</p>
	 <p>2,851</p>
	 <p>11,025</p>
 <p>Bevel pinion bearing rolling torque</p>	<p>daNm</p> <p>0,08 ÷ 0,12</p>
 <p>Adjustment of bevel pinion position</p>	 <p>by shims</p>
 <p>Thickness of shims</p>	<p>2,55 ÷ 3,35</p>
 <p>Differential internal casing bearing</p>	 <p>conical roller bearings</p>
 <p>Crown wheel bearings rolling torque</p>	<p>daNm</p> <p>0,18 ÷ 0,20</p>
 <p>Clearance between pinion and crown wheel</p>	<p>mm</p> <p>0,08 ÷ 0,15</p>

 <p>Adjustment of clearance between pinion and crown wheel</p>	
 <p>Adjustment of bearing pre-loading</p>	 <p>by shims</p>
 <p>Thickness of differential internal casing bearing pre-loading adjustment shims</p>	<p>0,18 ÷ 0,20</p>

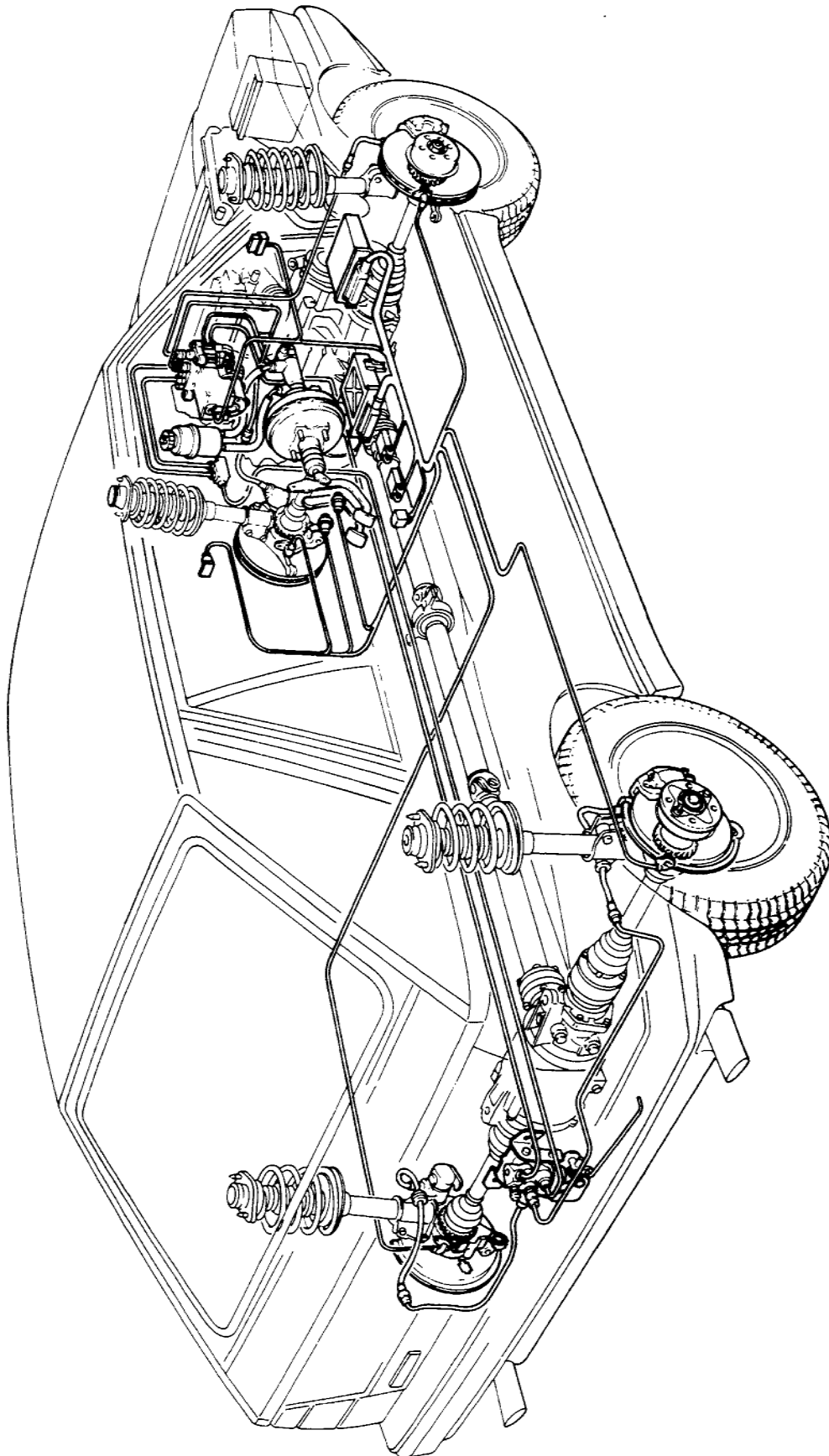


P1L29CA01

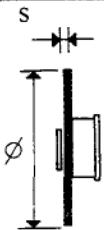



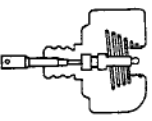
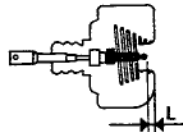
Parital diagrammatic cross section of rear axle

00.33

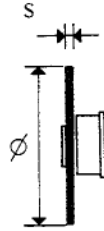




DIAGRAM SHOWING BRAKING SYSTEM

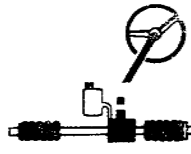



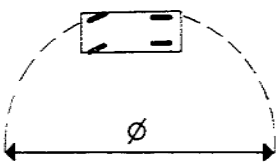


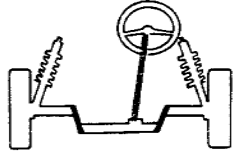



P1L28CA01




FRONT BRAKES		Values in mm	
	Disc	s {  < allowed	\varnothing 284
			$21,90 \div 22,10$
			20,9
			20,2
	Brake pads	$s <$ allowed	1,5
	Caliper	\varnothing	54
	Master cylinder (pump)	\varnothing	22,225 (7/8")
	Servo brake		ISOVAC 7"
	Distance of hydraulic piston push rod from master cylinder support plate	L	$0 \div 0,3$

REAR BRAKES

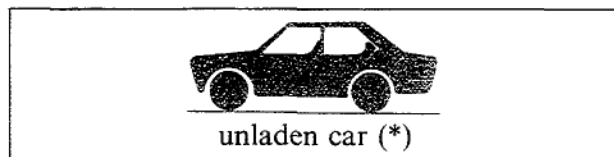
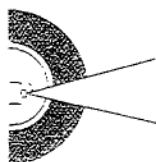
	Disc	s {  < allowed	\varnothing 227
			$10,70 \div 10,90$
			9,70
			9
	Brake pads	$s <$ allowed	1,5
	Caliper	\varnothing	34
	Load proportioning valve		acting on rear wheels
	Ratio (reduction)		0,36

<p>Type</p>	 <p>rack and pinion power assisted</p>
<p>Ratio</p> 	 <p>no. of turns lock to lock</p> <p>2,835</p>
<p>Ratio</p>	 <p>rack travel</p> <p>134 mm</p>
 <p>Minimum turning circle</p>	<p>10,4 m</p>
 <p>α_1</p>	<p>outer wheel α_1</p> <p>30°46'</p>
 <p>α_2</p> <p>Steering angle</p>	<p>inner wheel α_2</p> <p>35°4'</p>
 <p>Steering column</p>	 <p>with 2 universal joints</p>

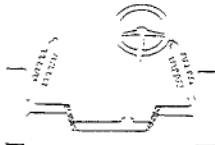


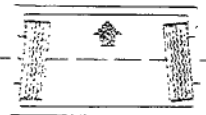



WHEELS

	Tyre		front	type	205/50 - VR 15
				average load	2 bar
			heavy load	2,2 bar	
			rear	average load	2 bar
heavy load	2,2 bar				
	Rim		type	light alloy 7Jx15"	

NOTE Spare wheel with 4J x 15" AH2 rim and 115/70 R15" XTL tyre
Speed limit: 80 km/h. Inflation pressure: 4,2 bar



WHEEL GEOMETRY

	Front suspension	camber (**)		$- 1' \pm 30'$
		caster (**)		$3^{\circ}10' \pm 30'$
		toe in		$- 2 \pm 1 \text{ mm } (\bullet)$
	Rear suspension	camber (**)		$- 1^{\circ}30' \pm 30'$
		toe in		$3 \div 5 \text{ mm } (\bullet)$

(*) With tyres inflated to the correct pressure and vehicle in running order
(**) Angles cannot be adjusted (●) Measured on a 360 mm diameter

00.44

Front suspension independent, Mac Pherson type with lower track control arm and damper comprising double acting telescopic shock absorber and offset coil spring.
Stabilizer bar

Coil spring

Diameter of wire	mm	13 ± 0,05
Number of turns		5,39
Direction of coil		clockwise
Height of spring released	mm	405,95
Height of spring under a load of 415,8 daN	mm	180,5
The springs are subdivided into two categories, identifiable by a mark: yellow (1) for those under a load of: 415,8 daN		> 180,5
green (1) for those under a load of: 415,8 daN		≤ 180,5

(1) Springs of the same category must be fitted.

Shock absorbers

Type: telescopic, hydraulic, gas double acting		Way-Assauto
Travel (start)	mm	151
Maximum extension (start)	mm	514,5

Rear suspension independent, Mac Pherson type with lower longitudinal track control arm and damper comprising double acting hydraulic telescopic shock absorber and offset coil spring.
Stabilizer bar

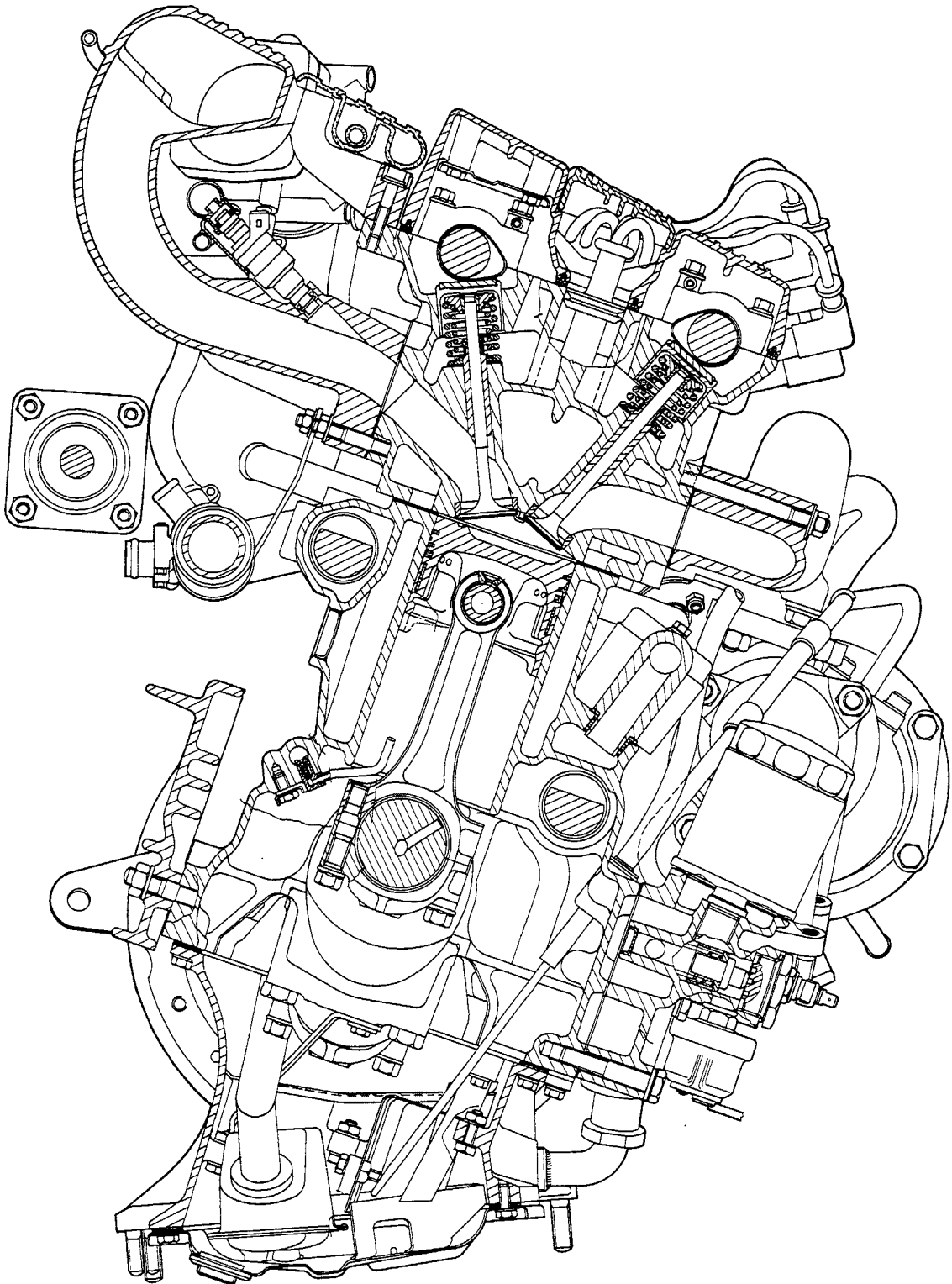
Coil spring

Diameter of wire	mm	12,1 ± 0,05
Number of turns		3,86
Direction of coil		clockwise
Height of spring released	mm	291
Height of spring under a load of 263 daN	mm	156,5
The springs are subdivided into two categories, identifiable by a mark:		
yellow (1) for those under a load of: 263 daN	having a height of mm	> 156,5
green (1) for those under a load of: 263 daN	having a height of mm	≤ 156,5

(1) Springs of the same category must be fitted.

Shock absorbers

Type: telescopic, hydraulic double acting		Way-Assauto
Travel (start)	mm	175
Maximum extension (start)	mm	575



P1L34CA01

Cross section of engine

SUMMARY

STARTER MOTOR	M. Marelli E70R - 1,4 kW - 12 V M. Marelli E95 - 1,1 kW - 12 V Bosch Ø94 - 0,95 kW - 12 V
ALTERNATOR	M. Marelli AA125R - 14 V - 65 A
VOLTAGE REGULATOR	M. Marelli RTT 119 AC
BATTERY	12 V - 45 Ah - 225 A
IGNITION SYSTEM	Weber (MPI) electronic injection/ignition
IGNITION DISTRIBUTOR	DT 543 D
IGNITION COIL	M. Marelli BAE 504 DK
IGNITION COIL WITH CONTROL MODULE	M. Marelli AEI 600 C
SPARK PLUGS	Fiat V45 LSR M. MARELLI F8 LCR Bosch WR6 DC Champion RN7 YC

Technical data

DELTA HF integrale 16v

Electrical equipment: starting

00.55

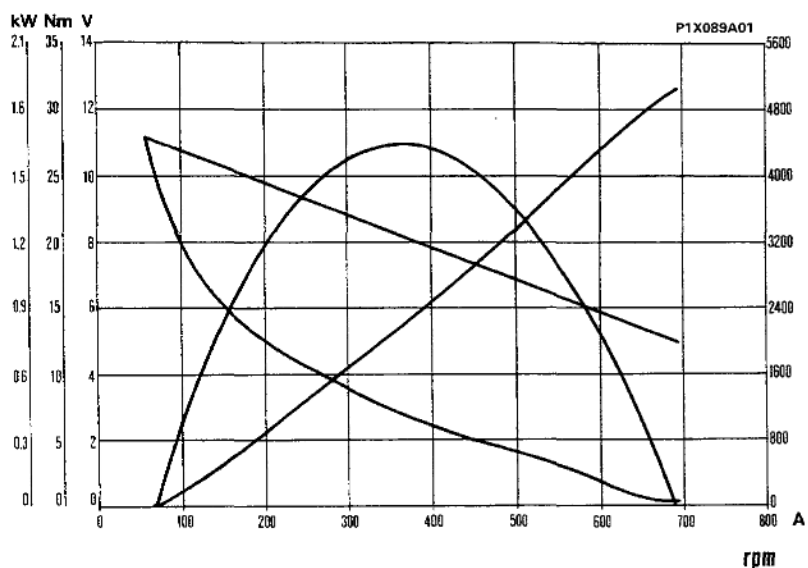
STARTER MOTOR

Type		M.MARELLI E70R-12V-1,4kW (with reduction gear)	M.MARELLI E95-12 V-1,1 kW	BOSCH Ø94-12 V-0,95 kW
Voltage	V	12		
Nominal power	kW	1,4	1,1	0,95
Rotation, pinion side		clockwise		
No. of poles		4		
Field coil		series winding	in series-parallel	series winding
Engagement		free wheel		
Operation		solenoid		
End float of armature shaft	mm	0,15 ÷ 0,45		
Data for bench test				
Operating test (*):				
current	A	360 ÷ 380	270	260
speed	rpm	1150	1750	1600
voltage	V	8,15	9,2	9,5
torque developed	daNm	1,30	0,65	0,70
Engagement test (*):				
current	A	680 ÷ 700	530 ÷ 570	460 ÷ 500
voltage	V	4,9	6,6	7,4
torque developed	daNm	3,11	≥ 1,60	≥ 1,50
Free running test (*):				
current	A	60 ÷ 80	35 ÷ 45	35 ÷ 45
voltage	V	11,1	11,6 ÷ 11,7	11,5
speed	rpm	4040	8500 ÷ 9500	9100 ÷ 10100
Relay				
Winding resistance (*)	pull in Ω	0,33 ÷ 0,37	0,33 ÷ 0,37	0,36 ÷ 0,38
	hold in Ω	1,13 ÷ 1,27	1,13 ÷ 1,27	1,6 ÷ 1,7
Lubrication				
Internal splines and shaft bushes		VS ⁺ SAE 10 W		
Engagement sleeve and intermediate disc		TUTELA MR3		

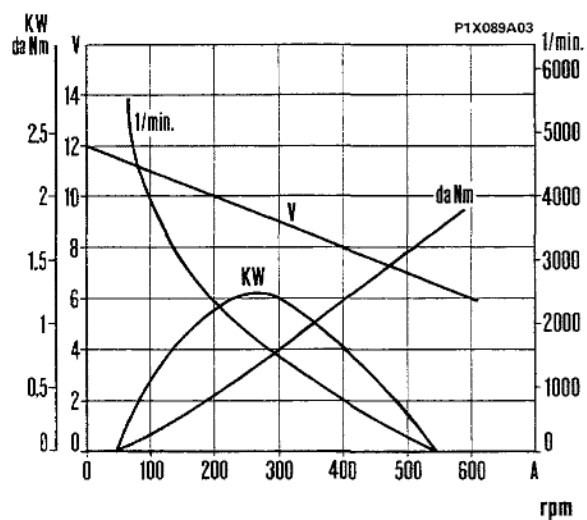
(*) Data obtained at an ambient temperature of 20°C.

NOTE When overhauling it is not advisable to undercut the insulator between the commutator bars

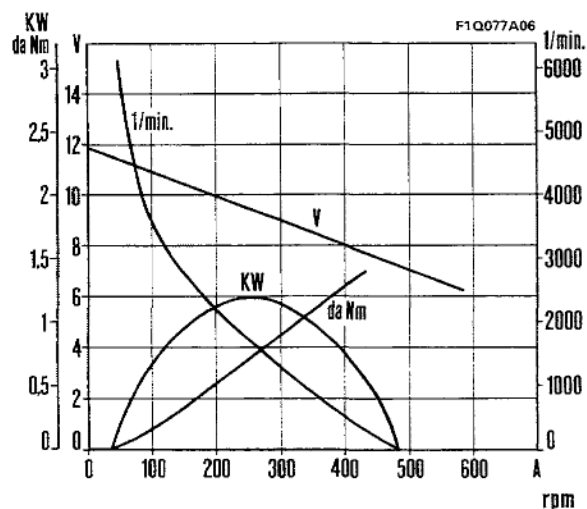
STARTER MOTOR – TYPICAL CURVES



M. Marelli E 70R - 12 V - 1,4 kW



M. Marelli E 95 - 1,1 kW - 12 V



Bosch Ø94 - 12 V - 0,95 kW

Technical data

DELTA HF integrale 16v

Electrical equipment: recharging

00.55

ALTERNATOR

Make and type		M. Marelli AA 125R - 14 V - 65 A
Nominal voltage	V	12
Maximum current	A	65
Cut in speed when warm	rpm	1050 ÷ 1150
Current delivery at the battery at 7000 rpm at operating temperature	A	≥63
Field winding resistance, between the slip rings (*)	Ω	2,6 ÷ 2,8
Direction of rotation (seen from control side)		clockwise
Engine/alternator transmission ratio		1 : 2
Diode rectifiers		bridge

(*) Data obtained at an ambient temperature of 25 °C.

VOLTAGE REGULATOR

Type		Built in electronic RTT 119 AC
Alternator speed for test	rpm	7000
Thermal stabilization current	A	30 ÷ 35
Test current	A	32 ÷ 33
Regulation voltage (*)	V	14 ÷ 14,3

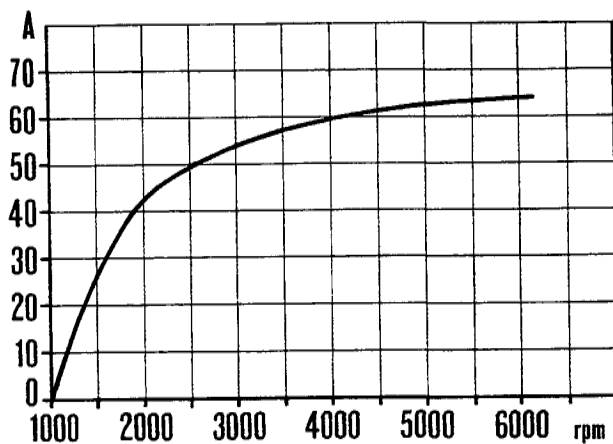
(*) Data obtained at an ambient temperature of 20 °C.

BATTERY

Nominal voltage	V	12
Capacity (20 hour discharge)	Ah	45

ALTERNATOR - TYPICAL OUTPUT CURVES

(at operating temperature, at a constant voltage of 13.5 V with bedded in brushes)

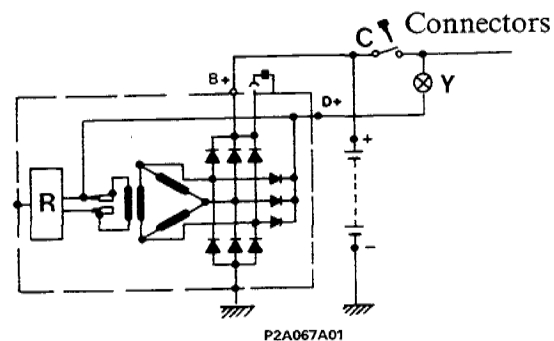


P2A067A02

M. Marelli AA 125 R - 14 V - 65 A

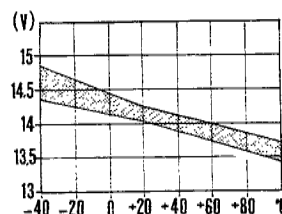
Wiring diagram for Marelli alternator

- C = Ignition switch with key
- Y = Battery recharging warning light (12V - 3/5W)
- R = Electronic voltage regulator



P2A067A01

Typical regulator voltage curve
FIMM RTT 119 AC



P2A065A07

Technical data

DELTA HF integrale 16v

Electrical equipment: electronic injection/ignition

00.55

ELECTRONIC IGNITION POWER MODULE

Make and type	M. Marelli AEI 600C
Firing order	1 - 3 - 4 - 2

DISTRIBUTOR

Make	M. Marelli
Type	DT 453 D
Built in rotor arm resistance Ω	1000
Electro-magnetic impulse generator coil winding resistance at 20 °C Ω	758 ÷ 872

IGNITION COIL

Make	M. Marelli
Type	BAE 504 DK
Ohmic resistance of primary winding at 20 °C Ω	0,415 ÷ 0,495
Ohmic resistance of secondary winding at 20 °C Ω	4320 ÷ 5280

TDC AND RPM SENSOR

Make and type	M. Marelli SEN 8 D
Sensor winding resistance Ω	612 ÷ 748
Distance (gap) between sensor and crankshaft pulley teeth mm	0,4 ÷ 1

ADVANCE ON ENGINE

Idling from 850 to 950 rpm	15° ± 2°
----------------------------	----------

SPARK PLUGS

Make and type	Fiat V 45 LSR	Bosch WR 6 DC	Champion RN7YC	M. Marelli F8LCR
Thread	M 14 × 1,25			
Electrode gap	0.6 ÷ 0.7 mm			

I.A.W. ELECTRONIC INJECTION SYSTEM COMPONENTS

DESCRIPTION	QUANTITY	TYPE
ELECTRONIC CONTROL UNIT	1	WH4W.08/90E-95
BUTTERFLY CASING	1	56 CFL 54
INJECTOR	4	IW 058
AUTOMATIC IDLE ADJUSTMENT SOLENOID VALVE	1	VAE 01/02
PRESSURE REGULATOR	1	RP7/2.5 bar
AIR TEMPERATURE SENSOR	1	ATS 04
WATER TEMPERATURE SENSOR	1	WTS 05
ABSOLUTE PRESSURE SENSOR	1	APS 02/03
	1	APS 05/01
BUTTERFLY VALVE POSITION SENSOR	1	PF 09/02
FUEL FILTER	1	FI 02/2
ELECTRIC FUEL PUMP	1	PI 022/12

Special tools

00.A

ENGINE

1840207814	Tool (Ø 18-22 mm) for removing counter balance shaft front bearings from crankcase (to be used with 1840206000)	1860490000	Fixture to retain valve tightness test device 1895868000 (to be used with 1860470000)
1850088000	Spanner (13 mm) for adjusting manifold fixing nuts	1860592000	Universal hook for lifting and moving engine-gearbox unit
1850113000	Wrench (12 mm) for engine oil draining plug	1860592010	Tool for removing and refitting engine-gearbox unit (to be used with 1860592000)
1852137000	Spanner, 1/2" socket, for cylinder head fixing bolts	1860605000	Band (Ø 60-125 mm) for fitting normal and oversize pistons in cylinders
1852150000	Spanner for bolts fixing tappet covers	1860644000	Tool, valve removal and refitting
1853003000	Spanner (19 mm) for bolt fixing camshaft gear, on vehicle	1860699000	Installer to fit crankshaft rear oil seal (to be used with 1870007000)
1854033000	Spanner for electric pump or fuel filter ring nut on tank	1860745100	Tool for toothed belts tensioning (to be used with specific parts)
1854038000	Spanner for fuel level sender ring nut on tank	1860745200	Tool for timing system toothed belt tensioning (to be used with 1860745100)
1860054000	Installer (22 mm dia), piston pin bush	1860745400	Tool to stretch timing system counterrotating shaft toothed belt (use with 1860745100)
1860162000	Pressure gauge with unions for checking engine oil pressure (scale 0-9,81 bar)	1860747000	Tool to hold tappets for replacing plates while adjusting valve clearance (to be used with 1860443000)
1860183000	Pliers (Ø 75-110 mm) for removing and refitting piston rings	1860758000	Tool to remove oil filter
1860303000	Installer, piston pin snap rings	1860765000	Tool for retaining camshaft toothed pulley.
1860395000	Drift, valve guides removal	1860768000	Tool for rotating crankshaft on vehicle
1860443000	Lever to insert tappet retainer during valve clearance adjustment	1860769000	Board to rest cylinder head during valve removal and refitting
1860454000	Installer, oil seal on valve guide	1860770000	Drift for fitting camshaft gaskets and crankshaft front gasket
1860456000	Cylinder head rest for use when replacing tappet plates (on bench vice)	1861001011	Pair of brackets to secure engine on rotating stand 1861000000
1860470000	Tool to rest cylinder head during overhauling		
1860486000	Drift, valve guides inserting		

- 1867028000** Pair of threaded pegs for crankshaft rotation (on bench)
- 1867029000** Flywheel lock
- 1876036000** Jumper for rotating engine when adjusting valve clearance
- 1890385000** Reamer (7 mm dia) for valve guide bores
- 1895362000** Cooling system leakage test equipment
- 1895683000** Device for checking engine cylinder compression (scale 4.05 - 18.2 bar)
- 1895683002** Cards for tool 1895683000
- 1895762000** Dynamometer to check V and poly-V belt tension
- 1895868000** Valve leakage test equipment
- 1895890000** Fuel pump delivery pressure gauge with unions
- 1896248000** Gauge for checking valve stem height after refacing bores in cylinder head

CLUTCH

- 1875029000** Clutch disk centering pin
- 1875084000** Tool for removing thrust bearing from clutch release mechanism

GEARBOX

- 1846001000** Half rings to withdraw gearbox main shaft bearing (engine side) (to be used with 1846017000)
- 1850113000** Wrench (12 mm), oil sump draining plug
- 1855035000** Spanner (19 mm) for removing and refitting gearbox
- 1870595000** Cross member for supporting engine whilst removing-refitting gearbox-differential unit

- 1870600000** Support to hold gearbox-differential assy during removal and installation
- 1871001014** Support for gearbox-differential unit whilst overhauling (to be fitted to 1861000000 or to **1871000000**)

FRONT AND REAR DIFFERENTIAL

- 1845062000** Tool to remove front axle shaft constant velocity joint (to be used with 1847017001)
- 1847017004** Plate to remove shaft from crown wheel (to be used with 1847017001)
- 1870100002** Drift for fitting front differential cover seal and bearing and front and rear differential pinion seal
- 1870152000** Drift to fit differential bevel pinion bearings inner race (1) rear bearing only
- 1870430000** Tool to gauge adjusting shim of front and rear differential bevel pinion (to be used with 1870404000, 1895884000 and 1895113000)
- 1870432000** Tool to retain front differential bevel pinion when handling lock nut
- 1870433000** Tool to check clearance between front differential pinion and ring gear (to be used with 1895684000)
- 1870434000** Tool to fit rear differential right flanged shaft seal (to be used with 1870007000)
- 1870435000** Tool to fit outer rings of front and rear differentials pinion bearings (to be used with 1870007000 and 1840005002)
- 1870436000** Support for front and rear differentials (operation at the bench)

00.A

- 1870437000** Tool to remove inner ring of front and rear differential bevel pinion shaft rear bearing (to be used with 1846017000)
- 1870438000** Tool to remove inner rings of front and rear differential case bearings (to be used with 1840005001, 1840005302 and 1840005400)
- 1870439000** Tool to check rolling torque of front differential case bearings and of rear differential bevel pinion bearings (to be used with 1895697000)
- 1870440000** Tool for checking contact of front and rear differential pinion/crown wheel teeth (to be used with 1870433000, 1870439000, 1870442000 and 1870443000)
- 1870441000** Tool to retain bevel pinion when handling lock nut and when checking rear differential pinion/ring gear clearance (to be used with 1895684000)
- 1870443000** Tool to check rolling torque of front differential case bearings and of rear differential bevel pinion bearings (to be used with 1895697000)
- 1870597000** Installer for differential cover oil seal (to be used with 1870007000)
- 1875017000** Tool to remove and refit differential bearing rings (to be used with 1840005003)
- 1875019000** Tool to remove and refit differential bearing rings (to be used with 1840005003)
- 1895655000** Tool to select differential bearing adjusting shims (to be used with 1895884000)

BRAKING SYSTEM

- 1856132000** Spanner (10-11 mm) for adjusting brake fluid pipe unions

STEERING

- 1847035000** Puller for steering rod ball pins

SUSPENSION AND WHEELS

- 1847017004** Plate for pulling wheel hub (to be used with 1847017001)
- 1854015000** Spanner (19 mm) for removing and refitting shock absorber fixing nut
- 1870152000** Drift for fitting bearing and hub on rear stub axle
- 1874555000** Pneumatic tool for compressing suspension springs when removing shock absorbers

ELECTRICAL EQUIPMENT

- 1850087000** Spark plug wrench
- 1857504000** Spanner (29 mm) for adjusting air conditioning system compressor pipe unions
- 1876046000** Lever to disconnect tag terminals from block
- 1895879000** Tool for checking cylinder no. 1 piston T.D.C. for positioning sensor carrier plate (static advance electronic ignition) (to be used with 1895881000)
- 1895895000** Tool for positioning sensor carrier plate, timing side (static advance electronic ignition)

BODYWORK

- 1859008000** Spanner for outer rear view mirror ring nut
- 1878017000** Pliers to clamp seat spring hooks
- 1878031000** Set of suction pads (4) for raising windscreen and rearscreen glass
- 1878076000** Tool to cut internal trimming plastic protection
- 1878077000** Tool to remove door trim panels or plastic buttons

ORDINARY TOOLS

1840005000	Puller, universal
1840206000	Percussion extractor (to be used with special tools)
1846017000	Base for puller half-rings
1847017001	Percussion extractor (to be used with special tools)
1861000000	Rotating stand for overhauling engine (also for gearboxes and differentials)
1861000001	Pair of sections for brackets supporting the engine on rotating stand 1861000000
1870007000	Universal handle
1870404000	Support for measuring depth and projection (to be used with 1895881000)
1871000000	Rotating column for overhauling gearboxes and differentials
1874549000	Support for vehicle rear and lifting (to be used with hydraulic jack)
1895113000	Gauge (0,05-0,10 ... 0,80 mm) for checking various clearances
1895684000	Dial gauge with magnetic base
1895697000	Dynamometer (0-4,90 Nm) for measuring bearing rolling torque
1895881000	Dial gauge to be used with special tools (measuring capacity 10 mm; shank length 16.7 mm)
1895884000	Dial gauge to be used with special tools (measuring capacity 5 mm; shank length 16.5 mm)

00.

DESCRIPTION	Thread size	Tightening torque
		daNm

ENGINE

Centre bearing cap to crankcase fixing, bolt	M 12 x 1,25	2 + 130°
Bearing caps to crankcase fixing, bolt	M 12 x 1,25	2 + 90°
Rod to aluminium guard and torque converter fixing, nut	M 10 x 1,25	5
One-way oil drain valve	3/8" 14 NPTF	5
Bracket to Ferguson joint aluminium guard, differential and bell housing fixing, nut	M8	2,5
Aluminium guard and bell housing rear brackets fixing, nut	M 10 x 1,25	5
Reaction mounting to torque converter fixing, bolt	M 12 x 1,25	9,5
Cylinder head to crankcase fixing, bolt	M 10 x 1,25	5 + 90° + 90°
Camshaft cap fixing, bolt	M 8	2,5
Inlet manifold to cylinder head fixing, nut	M 8	2,5
Exhaust manifold to cylinder head fixing, nut	M 8	2,5
Inlet manifold mounting to cylinder head fixing, bolt	M 8	2,5
Big end fixing, bolt	M 10 x 1	2,5 + 50°
Flywheel to crankshaft fixing, bolt	M 12 x 1,25	14,2
Poly-V belt and power assisted steering pump drive pulley fixing, bolt	M 8	2,5
Timing gear to crankshaft fixing, bolt*	M 14 x 1.5 Left hand	19
Belt tensioner bearing to mounting fixing, bolt	M 10 x 1,25	4,4
Belt tensioner mounting to alternator and power assisted steering mounting fixing, bolt	M 8	2,3
Poly-V belt tension adjustment screw stop, nut	M 10 x 1	4,4
Timing gear fixing, bolt	M 12 x 1,25	11,8
Camshaft belt tensioner bearing fixing, nut	M 10 x 1,25	4,4

* The bolt should not be lubricated

DESCRIPTION	Thread size	Tightening torques
		daNm
Counter balance shaft gear fixing, bolt	M 12 x 1,25	11,8
Counter balance shaft cover fixing, bolt	M 8	2,3
Counter balance shaft belt tensioner fixing, nut	M 8	2,3
Turbocharger to exhaust manifold fixing, nut	M 10 x 1,5	5,9
Union to turbocharger fixing, nut	M 10 x 1,5	5,9
Turbocharger mounting bracket to crankcase fixing, bolt	M 8	2,9
Turbocharger mounting bracket and exhaust pipe mounting bracket to crankcase fixing, nut	8	2,9
Oil supply pipe to turbocharger fixing, bolt	M 8	2,3
Filler for adjustable union fixing oil supply pipe to oil filter mounting	M 14 x 1,5	5
Oil supply pipe support bracket to exhaust manifold fixing, bolt	M 10 x 1,25	4,3
Oil return pipe from turbocharger to sump fixing, bolt	M 8	2,3
Filler for adjusting union fixing coolant supply and return pipes to the turbocharger	M 16 x 1,5	3,2
Oil filter mounting and engine mounting to crankcase fixing, bolt	M 10 x 1,25	4,3
Plug for thermostatic valve on oil filter mounting	M 35 x 1,5	11,8
Oil level dip stick fixing, bolt	M 8	2,5
Water pump to crankcase fixing, bolt	M 8 x 1	2,5
Water pump union to casing fixing, bolt	M 8	2,3
Accelerator outer cable reaction bracket to inlet manifold fixing, bolt	M 8	2,5
Coolant return pipe to inlet manifold fixing, nut	M 8	2,3
Thermostat to cylinder head fixing, nut	M 8	2
Complete coolant return pipe to cylinder head fixing, bolt	M 8	2,3

00.

DESCRIPTION	Thread size	Tightening torques
		daNm
Water pump drive pulley to hub on pump bearing fixing, bolt	M 8	2,5
Alternator and power assisted steering pump mounting to crankcase fixing, nut	M 10 x 1,25	4,3
Alternator and power assisted steering pump mounting to crankcase fixing, bolt	M 10 x 1,25	4,3
	M 8	2,5
Alternator bracket to mounting fixing, bolt	M 10 x 1,25	4,3
Alternator bracket fixing, nut	M 10 x 1,25	4,3
Alternator fixing, nut	M 12 x 1,25	6,9
Support brackets to power assisted steering pump fixing, bolt	M 8	2
Power assisted steering pump support brackets to mounting fixing, bolt	M 10 x 1,25	4,3
Power assisted steering driven pulley fixing, nut	M 14 x 1,5	9,5
Spark plugs	M 14 x 1,25	3,7
Oil temperature sender unit	M 14 x 1,5	3,7
Coolant temperature sender unit	M 16 x 1,5 tapered	4,9
Oil pressure switch	M 14 x 1,5	3,2
Oil sump plug	M 22 x 1,5 tapered	5

FUEL CIRCUIT

Fuel pump immersed in tank fixing, ring nut	131 x 6	6
Fuel level gauge to tank fixing, ring nut	81 x 4	3
Filler for adjustable union fixing fuel supply pipe to filter (aluminium filter housing)	M 14 x 1,5	3,5
Filler for adjustable union fixing fuel supply pipe to filter (steel filter housing)	M 14 x 1,5	4
Filler for adjustable union fixing fuel supply pipe to filter	M 12 x 1,5	3,5
Nut for union fixing fuel pipe between filter and injector manifold to manifold	M 14 x 1,5	3,5

DESCRIPTION	Thread size	Tightening torques
		daNm

LUBRICATION CIRCUIT

Nuts at end of flexible oil supply pipe between engine and radiator	M 22 x 1,5	5
Nuts at end of flexible oil return pipe between radiator and engine	M 22 x 1,5	5
Engine oil cooling radiator fixing, bolt	M 6 x 1	1

ENGINE EXHAUST

Exhaust pipe to turbocharger fixing, nut for stud	M 10 x 1,5	3,7
Flanges for fixing silencers to exhaust pipe fixing, bolt	M 8 x 1,25	1,5
Exhaust pipe mounting bracket to collar fixing, bolt	M 10 x 1,25	5
Collar on exhaust pipe to bracket fixing, nut	M 8 x 1,25	2,5
Exhaust pipe to flexible mounting fixing, nut	M 8 x 1,25	1

POWER UNIT MOUNTING

Power unit mounting flexible mounting support, engine side, fixing, bolt	M 8 x 1,25	1,7
Flexible mounting, engine side, to engine, fixing, bolt	M 12 x 1,25	5
Flexible mounting to engine side support fixing, bolt	M 10 x 1,25	3,1
Power unit anchoring rod, engine side, fixing, bolt	M 10 x 1,25	4,2
Power unit anchoring rod, bodyshell side, fixing, bolt	M 10 x 1,25	4,2
Flexible mounting bracket, gearbox side, fixing, bolt	M 8 x 1,25	1,6
Flexible mounting to gearbox side bracket fixing, bolt	M 12 x 1,25	8,5
Flexible mounting support to bodyshell, gearbox side, fixing, bolt	M 10 x 1,25	3,5
Flexible mounting brackets, gearbox side, fixing, bolt	M 10 x 1,25	6
Flexible mounting to gearbox side mounting fixing, bolt	M 10 x 1,25	6
Complete flexible mounting to gearbox fixing, nut	M 10 x 1,25	6

00.

DESCRIPTION	Thread size	Tightening torques
		daNm
Complete flexible mounting, gearbox side, fixing, bolt	M 12 x 1,25	8,5
Central attachment flexible mounting bracket fixing, nut	M 12 x 1,25	5
Centre flexible mounting bracket to differential fixing, bolt	M 10 x 1,25	5
Centre flexible mounting to supports fixing, bolt	M 12 x 1,25	8,5
Centre mounting to bodyshell side support fixing, bolt	M 10 x 1,25	3,1
Centre mounting support to bodyshell fixing, bolt	M 8 x 1,25	1,8

CLUTCH

Clutch mechanism to flywheel fixing, bolt	M 8 x 1,25	2
Nut for bolt hinging brake and clutch pedals	M 8 x 1,25	2,3
Pedals to bodyshell fixing, bolt	M 8 x 1,25	2,3
		1,4

MANUAL GEARBOX-DIFFERENTIAL

Clutch release sleeve mounting cover fixing, bolt	M 6 x 1	0,75
Left side cover to casing fixing, bolt	M 8 x 1,25	2,5
Gearbox casing to support fixing, bolt	M 8 x 1,25	2,5
Rear cover to gearbox casing fixing, bolts	M 8 x 1,25	2,5
Support fixing gearbox assembly to engine, nut for stud	M 12 x 1,25	8,5
Differential cover to engine-gearbox mounting fixing, bolt (length 55 mm)	M 8 x 1,25	2,5
Differential cover to engine-gearbox mounting fixing, bolt (length 80 mm)	M 10 x 1,25	5
Gear control rod spring retaining, bolt	M 8 x 1,25	2,5
Magnetic plug	M 22 x 1,5	4,6
Main shaft gears locking, ring nut	M 22 x 1,5	15

DESCRIPTION	Thread size	Tightening torques
		daNm

Lay shaft gears locking, ring nut	M 22 x 1,5	15
Main rear bearing retaining plate fixing, bolt	M 8 x 1,25	2,5
Lay shaft rear bearing retaining plate fixing, bolt	M 8 x 1,25	2,5
1st and 2nd speed selector fork fixing, bolt	M 8 x 1,25	2,5
3rd and 4th speed selector fixing, bolt	M 8 x 1,25	2,5
3rd and 4th speed selector fork fixing, bolt	M 8 x 1,25	2,5
5th speed and reverse selector fixing, bolt	M 8 x 1,25	2,5
Complete reverse gear lever fixing bolt	M 8 x 1,25	2,5
5th speed selector fork fixing, bolt	M 8 x 1,25	2,5
Gearbox control shaft bush to casing fixing, bolt	M 6 x 1	0,75
Gear control lever to internal shaft fixing, nut	M 8 x 1,25	2,5
Gear control lever to external shaft fixing, bolt	M 8 x 1,25	2,5
Speedometer mounting fixing, bolt	M 6 x 1	1
Crown wheel fixing, bolt	M 8 x 1,25	3,5
Reversing light switch, bolt	M 12 x 1	3
Drive shaft joints to front differential fixing, bolt	M 8 x 1,25	4,2

EXTERNAL GEARBOX CONTROLS

Gear engagement control rod rear flexible mounting fixing, bolt	M 6 x 1	0,6
Gear engagement control lever joint to rod fixing, bolt	M 6 x 1	0,9
Gear engagement lever to floating mounting fixing, bolt	M 6 x 1	0,6
Flexible bush on gear engagement control rod fixing, bolt (flexible joint)	M 6 x 1	0,9

00.

DESCRIPTION	Thread size	Tightening torques
		daNm

Gear engagement control rod to gearbox output rod fixing, bolt	M 10 x 1,25	3,5
End of gear engagement control rod to flexible bush fixing, bolt	M 6 x 1	0,9
Bracket fixing reaction rod flexible bush to gearbox fixing, bolt	M 8 x 1,25	2
Mounting for reaction rod flexible bush to bracket on gearbox fixing, nut	M 8 x 1,25	1,3

ENGINE-GEARBOX FIXINGS

Bell housing to engine fixing, nut	M 12 x 1,25	8
Bell housing to engine fixing, bolt	M 12 x 1,25	8,5
Flywheel cover to bell housing fixing, bolt	M 6 x 1	0,8
Starter motor to bell housing fixing, bolt	M 8 x 1,25	2,2
Bell housing to engine fixing, bolt	M 12 x 1,25	5,5

FRONT DIFFERENTIAL: IDLER GEAR

Joint support fixing, bolt	M 8 x 1,25	2,5
Join support cover fixing, bolt	M 6 x 1	0,75
Cover for front differential mounting casing-idler gear fixing, bolt	M 8 x 1,25	2,5
Cover for front differential mounting casing-idler gear fixing, bolt	M 10 x 1,25	5
Bevel pinion locking, nut to be staked	M 20 x 1,5	17 ÷ 28
Crown wheel fixing, bolt	M 10 x 1,25	8,8

FRONT DIFFERENTIAL TO CONVERTER FIXINGS

Filler for adjustable union fixing oil supply pipe to bevel pinion mounting	M 16 x 1,5	3,5
Direct terminal union for fixing oil supply pipe to bevel pinion mounting	M 16 x 1,5	3,5
Front differential rod to engine sump fixing, nut	M 10 x 1,25	5,1

DESCRIPTION	Thread size	Tightening torques
		daNm

Bevel pinion mounting to gearbox fixing, bolt	M 12 x 1,25	8,8
Bevel pinion mounting fixing, bolt	M 8 x 1,25	2,5

PROPELLER SHAFT

Propeller shaft to front differential fixing, bolt	M 8 x 1,25	4,2
Propeller shaft intermediate support cross member fixing, nut	M 8 x 1,25	1,5
Nut for stud on rear differential fixing propeller shaft	M 10 x 1,25	5
Propeller shaft safety cross member fixing, nut	M 6 x 1	0,6
Propeller shaft shield fixing, nut	M 8 x 1,25	1

REAR DIFFERENTIAL

Pinion locking, nut to be staked	M 20 x 1,5	17 ÷ 28
Crown wheel fixing, bolt	M 10 x 1,25	8
Magnetic, threaded, tapered oil drain plug	M 22 x 1,5	4,6
Left cover fixing, bolt	M 10 x 1,25	5
Threaded, tapered, oil filler plug	M 22 x 1,5	4,6
Right cover fixing, bolt	M 8 x 1,25	2,5
Nut for stud on right cover	M 8 x 1,25	2,5
Differential flexible mounting to rear cross member fixing, nut	M 8 x 1,25	1,5
Rear differential to flexible mounting on rear cross member fixing, bolt	M 14 x 1,5	8,7

BRAKING SYSTEM

Front brake caliper to steering knuckle fixing, bolt	M 12 x 1,5	8,8
Rear brake caliper to stub axle fixing, bolt	M 10 x 1,25	4,8

00.

DESCRIPTION	Thread size	Tightening torques
		daNm

Front and rear brake discs to hub fixing, bolt	M 8 x 1,25	1,2
Front and rear brake discs to hub fixing, bolt	M 8 x 1,25	2,3
Brake shield fixing, bolt	M 6 x 1	0,9
Brake servo to pedals fixing, nut	M 8 x 1,25	1,4
Male union for pipes with inflated ends for fixing rigid pipe to servo brake pump	M 10 x 1	1,8
Male union for pipes with inflated ends for fixing rigid pipe to flexible pipe on front and rear brake calipers	M 10 x 1	1,8
Male union for pipes with inflated ends for fixing rigid pipes to load proportioning valve	M 10 x 1	1,8
Union for fixing rigid pipes to load proportioning valve	M 12 x 1	1,8
Union for fixing flexible pipes to brake calipers	M 10 x 1	2,1
Load proportioning valve to rear cross member fixing, bolt	M 8 x 1,25	2
Handbrake to vehicle floor fixing, nut	M 8 x 1,25	1,4

STEERING

Steering rod ball joint to steering knuckle fixing, nut	M 10 x 1,25	3,5
Power assisted steering to bodyshell fixing, bolt	M 8 x 1,25	2,1
Side steering rod fixing, nut	M 12 x 1,5	6
Steering control rod shaft universal joint fork fixing, bolt	M 8 x 1,25	2
Steering wheel to steering column fixing, nut (for steering wheel with aluminium hub)	M 16 x 1,5	3,7
Steering wheel position adjustment device fixing, nut (tighten the nut to the recommended torque with the lever in the locked position)	M 12 x 1,25	2,5
Steering column to mounting fixing, bolt	M 6 x 1	0,5
Filler for oil supply pipe adjustable union on power assisted steering pump	M 14 x 1,5	2,3

DESCRIPTION	Thread size	Tightening torques
		daNm

Filler for oil return pipe adjustable union on power assisted steering pump	M 18 x 1,5	3,4
Filler for oil supply pipe adjustable union on power assisted steering pump	M 14 x 1,5	2,3
Oil reservoir to mounting fixing, bolt	M 6 x 1	0,5

FRONT SUSPENSION

Ball joint to steering knuckle fixing, bolt	M 8 x 1,25	3,5
Ball joint to suspension arm fixing, bolt	M 8 x 1,25	3
End pins to suspension arm fixing, bolt	M 10 x 1,25	5,6
End pins to suspension arm fixing, bolt	M 10 x 1,25	5,6
Flexible bushes to suspension arm and end pins fixing, nut	M 10 x 1,25	4,5
Brackets (for suspension arm flexible bushes) to bodyshell fixing, nut	M 10 x 1,25	4
Right and left bracket to flexible bush bracket fixing, bolt	M 10 x 1,25	4
Shock absorber to steering knuckle fixing, bolt	M 10 x 1,25	5,5
Shock absorber stem to flexible mounting fixing, nut with polyamide ring	M 12 x 1,25	5
Flexible mounting at end of shock absorber stem to suspension turret fixing, nut	M 8 x 1,25	1,8
Bracket (for flexible mounting at end of anti-roll bar) to suspension arm fixing, nut	M 8 x 1,25	1
Bolt for tightening clamps to anti-roll bar	M 8 x 1,25	1,9
Flexible mounting (supporting anti-roll bar) to bodyshell fixing, bolt	M 8 x 1,25	1,2
Right and left bracket to complete right and left reinforcement fixing, bolt	M 10 x 1,25	3,5
Rod to suspension track control arm fixing, bolt	M 10 x 1,25	6
Wheel hubs to constant velocity joints fixing, nut	M 20 x 1,5	36
Wheel to hub fixing, bolt	M 12 x 1,25	8,6

00.

DESCRIPTION	Thread size	Tightening torques
		daNm

REAR SUSPENSION

Shock absorber to flexible mounting fixing, nut	M 12 x 1,25	5
Shock absorber to rear stub axle fixing, bolt	M 10 x 1,25	5,8
Complete flexible mounting to bodyshell turret fixing, nut	M 8 x 1,25	1,8
Anti-roll bar joint to bodyshell fixing, nut	M 8 x 1,25	1,2
Anti-roll bar to joint mounting fixing, bolt	M 6 x 1	1
Anti-roll bar to stub axle fixing, bolt	M 8 x 1,25	2,3
Rear cross member to bodyshell fixing, bolt	M 12 x 1,25	6
Longitudinal rods fixing, bolt	M 10 x 1,25	6
Transverse rods fixing, bolt	M 10 x 1,25	6
Wheel hubs to constant velocity joints fixing, nut	M 20 x 1,25	29,4
Wheels to rear hub fixing, bolt	M 12 x 1,25	8,6

BODYWORK

Upper hinge to bonnet lid and lower hinge to bracket fixing, bolt	M 8 x 1,25	0,8
Ball joint for bodyshell side and tailgate side, fixing	M 8 x 1,25	1,5
Moveable hinge to tailgate reinforcement fixing, bolt	M 8 x 1,25	1,5
Tailgate to bodyshell fixed hinge fixing, nut	M 6 x 1	0,4
Tailgate to bodyshell fixed side hinge fixing, nut	M 6 x 1	1
Tailgate lock striker to reinforcement fixing, bolt	M 6 x 1	1
Rear doors upper and lower hinge to bodyshell fixing, bolt	M 10 x 1,25	3,5
Front doors upper and lower hinge to door fixing, bolt	M 10 x 1,25	3,5
Front and rear doors upper and lower hinge to bodyshell fixing, bolt	M 10 x 1,25	3

DESCRIPTION	Thread size	Tightening torques
		daNm
Front and rear door lock to door fixing, bolt	M 6 x 1	0,25
Front and rear door lock striker to bodyshell fixing, bolt	M 8 x 1	2,5
	M 6 x 1	1
Front bumper bracket to bodyshell fixing, bolt	M 10 x 1,25	4,5
Rear bumper bracket to bodyshell fixing, bolt	M 10 x 1,25	3
Front side bumper to bracket fixing, bolt	M 8 x 1,25	1,2
Front and rear centre bumper to bracket fixing, bolt	M 10 x 1,25	3
Rear centre bumper fixing, bolts with nut with polyamide insert	M 10 x 1,25	3
Front and rear bracket for battery holder to bodyshell fixing, bolt	M 8 x 1,25	1,5
Battery holder to bodyshell side partition fixing, nut	M 8 x 1,25	0,9
Front and rear mounting to battery holder fixing, bolt	M 8 x 1,25	1,5
Lock to fuel filler flap fixing, nut	M 6 x 1	0,4
Front seats to bodyshell fixing, bolt	M 8 x 1,25	3,2
Front seats to mounting fixing, bolt	M 8 x 1,25	3,2
Bracket for fixing hoist for lifting and moving vehicle to bodyshell fixing, bolt	M 10 x 1,25	6,1
Front plate fixing vehicle to cross member fixing, bolt	M 10 x 1,25	3